

LCD-KIT-F Series

New

Slim Open Frame Monitor

IEI LCD monitor series is designed for system manufacturers, integrators, or value-added resellers that want to provide all the performance, quality and reliability of an LCD display solution at a cost effective price. The open front panel can be combined with any front bezel design, and makes installation easier and efficient, which is ideal for various embedded markets.

Features

- 12.1"~19" open frame architecture for embedded integration
- Over 350cd/m² high brightness and 50000hrs MTFB long lifetime panel
- Analog VGA or digital DVI interfaces support most of general systems
- Various touch panel solution : Resistive / Resistive touch windows / PCAP multi-touch
- Optional 9-36V DC module
- -20°C~60°C extended operating temperature
- Support software OSD for remote control applications



Automated Parking System



Machine Automation



Vending Machine



Kiosk

Wide Temperature Support

Support -20°C~60°C wide range temperature
Ideal for outdoor or semi-outdoor applications



Slim Design

Slim design, 20% thinner than LCD-KIT series

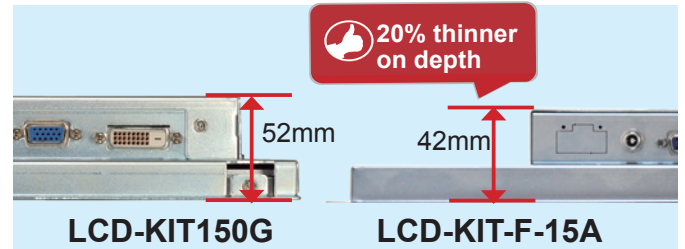

Flexible Mounting Support

Panel Mount

- With clamps and M5 screw



Rear Mount

- M3 screw holes

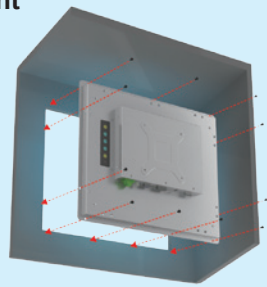

VESA Mount

- VESA 100

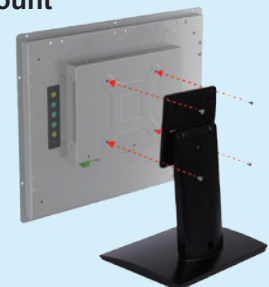

1

Industrial Computing Solutions

2

Video Capture Solutions

3

Industrial Computer Chassis

4

Open Frame Monitor

5

Power Supply/ Peripherals

6

All-in-One System

Clean Room

The LCD-KIT-F series can be shipped with touchscreen bonded or separated. Air-bonding method will be taken for Air Bonding resistive type or capacitive type touchscreen. IEI Integration Corp. has a Class 10,000 LCD clean room with ISO certification. It brings add-on value, cost efficiency and higher quality to our products.

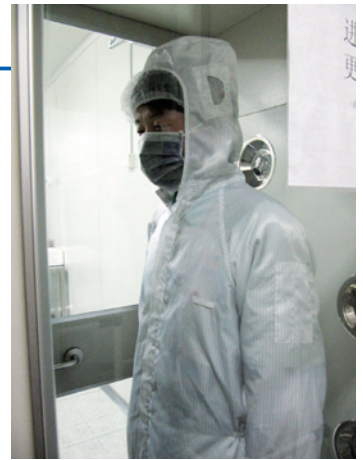

Control room particle measure result: Class 10000



Various Touch and Power Options

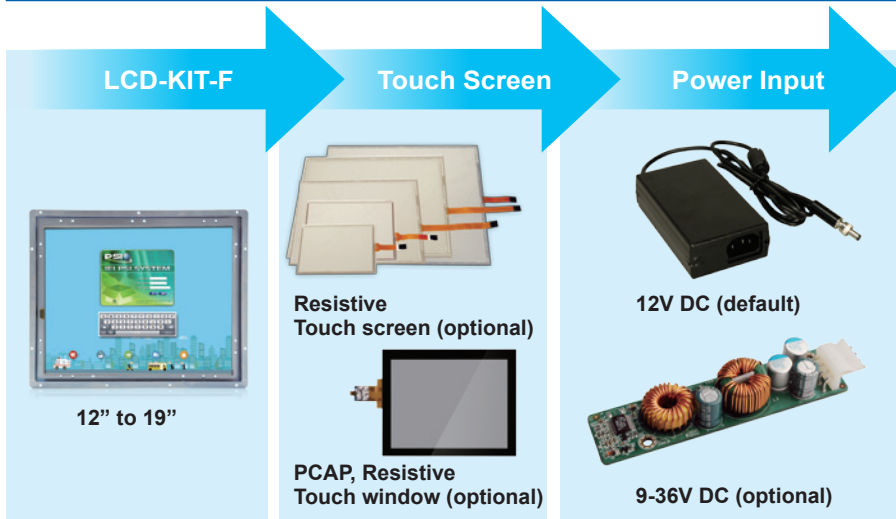

Product Line	LCD-KIT-F Series
LCD Size	12.1"~19"
Input Signal Interface	VGA+DVI-D
Brightness (cd/m ²)	350~600
DC Input	12VDC or 9~36VDC
Touch Screen	Resistive touch screen/Resistive touch window/PCAP touch screen
IEI samrtOSD	Yes

1 Industrial Computing Solutions

2 Video Capture Solutions

3 Industrial Computer Chassis

4 Open Frame Monitor

5 Power Supply/ Peripherals

6 All-in-One System

I/O Interface

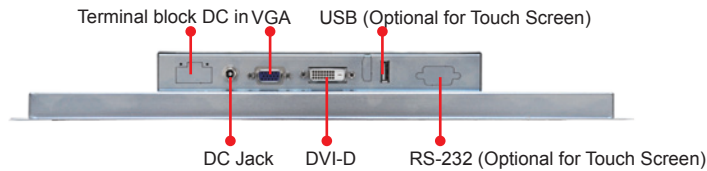

OSD Keypad

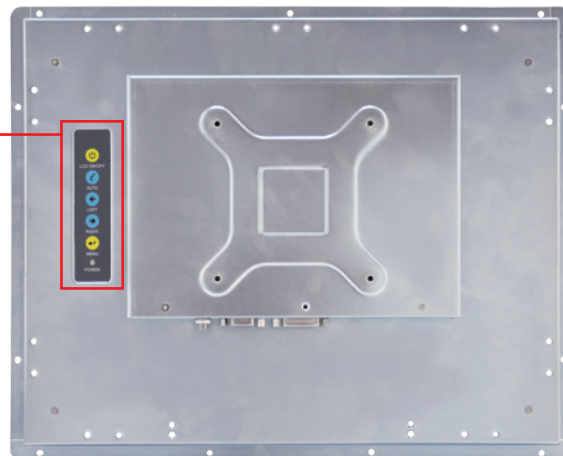
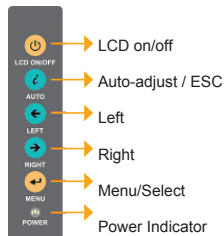

Specifications



Model	LCD-KIT-F12A	LCD-KIT-F15A	LCD-KIT-F17A	LCD-KIT-F19A
LCD Size	12.1"	15"	17"	19"
Resolution	1024 x 768	1024 x 768	1280 x 1024	1280 x 1024
Brightness (cd/m ²)	600	450	350	350
Contrast Ratio	700:1	800:1	800:1	1000:1
Display Color	16.2M	16.2M	16.7M	16.7M
Pixel Pitch (mm)	0.24	0.297	0.264	0.294
Viewing Angle (H/V)	160°/140°	160°/150°	170°/160°	170°/160°
Input Interface	Analog VGA, DVI-D, RS-232/USB (Optional for Touch)			
Touchscreen & controller	Resistive type 5-wire single touch / Penmount 6000 or Projected capacitive 2-point touch / EETI EXC7200 (Assembly by adhesive tape)			
OSD Function	5-key OSD			
smartOSD	Yes			
Dimensions (W x H x D) (mm)	323.8 x 263.8 x 40.3	380.1 x 304.6 x 43.2	410 x 343 x 49.4	449 x 374 x 49.45
Operating Temperature	-20°C~60°C			
Storage Temperature	-20°C~70°C			
Input Voltage	12VDC			
Construction Material	sheet metal rear cover SPCC			
Mounting	Panel Mount, Rear Mount, VESA 100			

Ordering Information

P/N	Description
LCD-KIT-F12A-R10	12.1" 600 cd/m ² XGA open frame monitor, VGA and DVI-D input, R10
LCD-KIT-F15A-R10	15" 450 cd/m ² XGA open frame monitor, VGA and DVI-D input, R10
LCD-KIT-F17A-R10	17" 350 cd/m ² SXGA open frame monitor, VGA and DVI-D input, R10
LCD-KIT-F19A-R10	19" 350 cd/m ² SXGA open frame monitor, VGA and DVI-D input, R10

Resistive Touch

P/N	Description
LCD-KIT-F12A/R-R10	12.1" 600 cd/m ² XGA open frame monitor, VGA and DVI-D input, Resistive touch screen RS-232/USB interface,R10
LCD-KIT-F15A/R-R10	15" 450 cd/m ² XGA open frame monitor, VGA and DVI-D input, Resistive touch screen RS-232/USB interface,R10
LCD-KIT-F17A/R-R10	17" 350 cd/m ² SXGA open frame monitor, VGA and DVI-D input, Resistive touch screen RS-232/USB interface,R10
LCD-KIT-F19A/R-R10	19" 350 cd/m ² SXGA open frame monitor, VGA and DVI-D input, Resistive touch screen RS-232/USB interface,R10

Flat Resistive Touch

P/N	Description
LCD-KIT-F12A/TW-R10	12.1" 600 cd/m ² XGA open frame monitor, VGA and DVI-D input, Resistive touch window RS-232/USB interface,R10
LCD-KIT-F15A/TW-R10	15" 450 cd/m ² XGA open frame monitor, VGA and DVI-D input, Resistive touch window RS-232/USB interface,R10
LCD-KIT-F17A/TW-R10	17" 350 cd/m ² SXGA open frame monitor, VGA and DVI-D input, Resistive touch window RS-232/USB interface,R10
LCD-KIT-F19A/TW-R10	19" 350 cd/m ² SXGA open frame monitor, VGA and DVI-D input, Resistive touch window RS-232/USB interface,R10

Flat P-CAP Touch

P/N	Description
LCD-KIT-F12A/PC-R10	12.1" 600 cd/m ² XGA open frame monitor, VGA and DVI-D input, Projected capacitive touch window USB interface,R10
LCD-KIT-F15A/PC-R10	15" 450 cd/m ² XGA open frame monitor, VGA and DVI-D input, Projected capacitive touch window USB interface,R10
LCD-KIT-F17A/PC-R10	17" 350 cd/m ² SXGA open frame monitor, VGA and DVI-D input, Projected capacitive touch window USB interface,R10
LCD-KIT-F19A/PC-R10	19" 350 cd/m ² SXGA open frame monitor, VGA and DVI-D input, Projected capacitive touch window USB interface,R10

9~36VDC Module

P/N	Description
LCD-KIT-F-936160-R10	60W DC/DC 9~36V input 12V output power kit, R10



Options

Description	Part Number
DVI cable	32000-086600-RS
RS-232 cable (for Touch)	32005-001100-200-RS
Panel mount kit	FRK-01-R10 (LCD-KIT-F12A/LCD-KIT-F15A)
	FRK-02-R10 (LCD-KIT-F17A/LCD-KIT-F19A)

Packing List

Item	P/N	Q'ty
AC power adapter	63040-010036-121-RS	1
AC power cable		1
USB cable (for Touch)	32001-006100-200-RS	1
VGA cable	32000-036200-RS	1
Utility CD		1

1

Industrial Computing Solutions

2

Video Capture Solutions

3

Industrial Computer Chassis

4

Open Frame Monitor

5

Power Supply/ Peripherals

6

All-in-One System

LCD-KIT-F-12A Dimensions (Unit: mm)

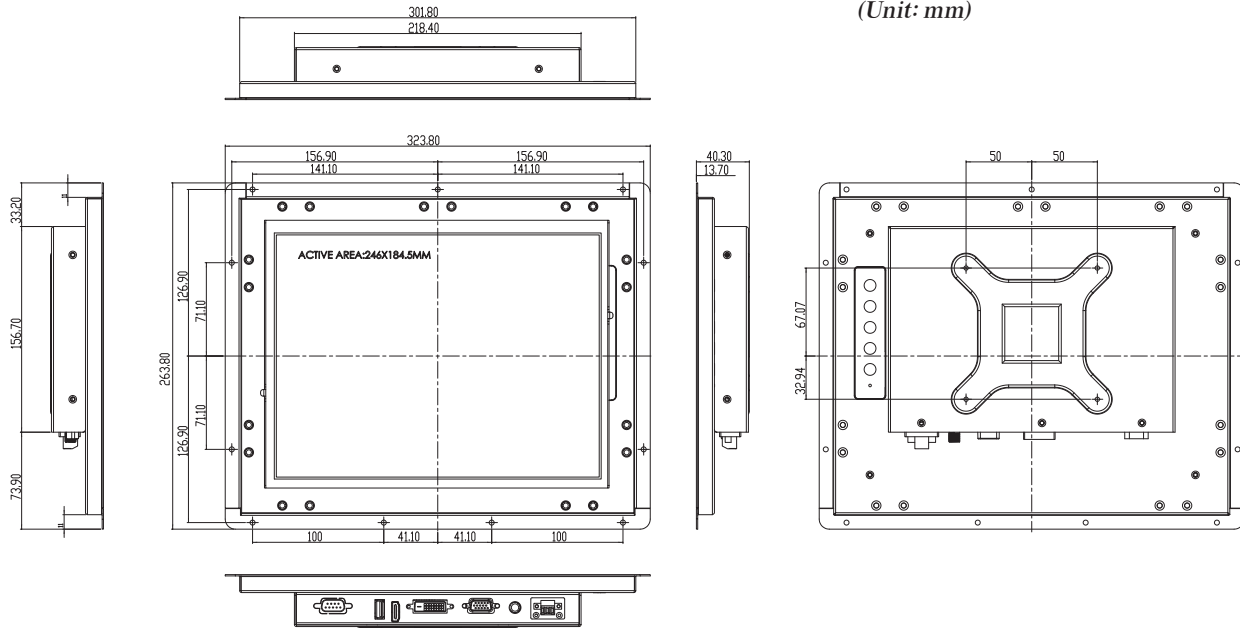

LCD-KIT-F-15A Dimensions (Unit: mm)

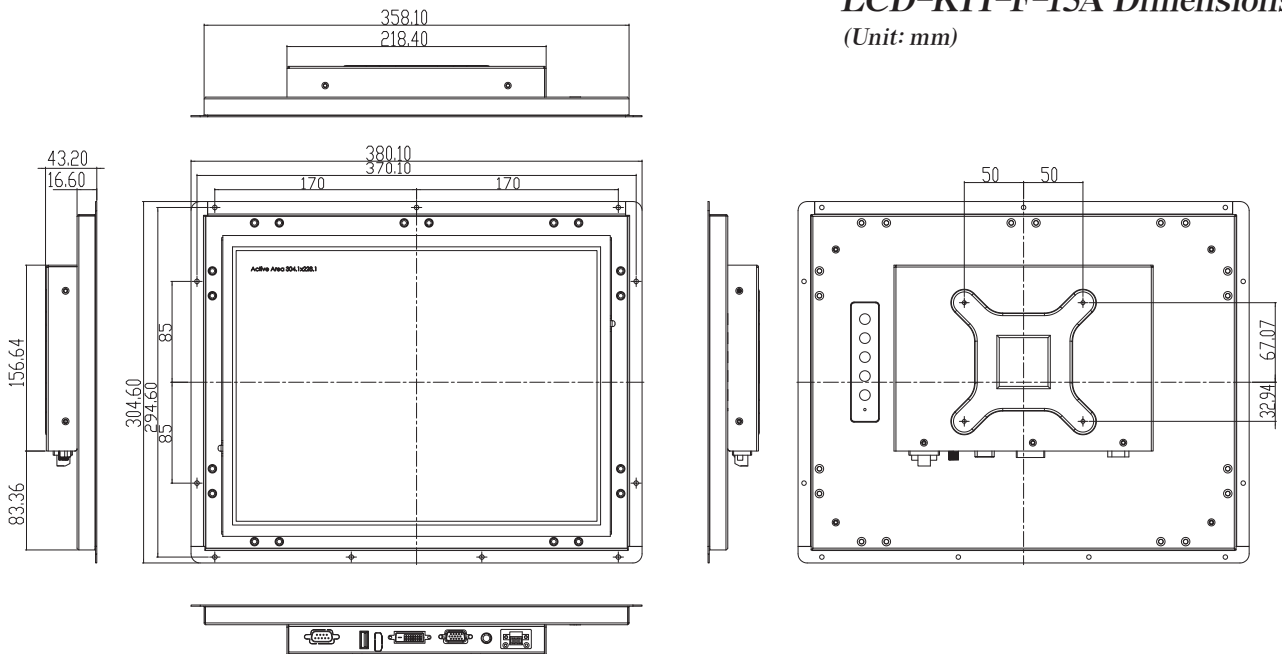

1

Industrial
Computing
Solutions

2

Video
Capture
Solutions

3

Industrial
Computer
Chassis

4

Open
Frame
Monitor

5

Power Supply/
Peripherals

6

All-in-One
System

LCD-KIT-F-17A Dimensions
(Unit: mm)

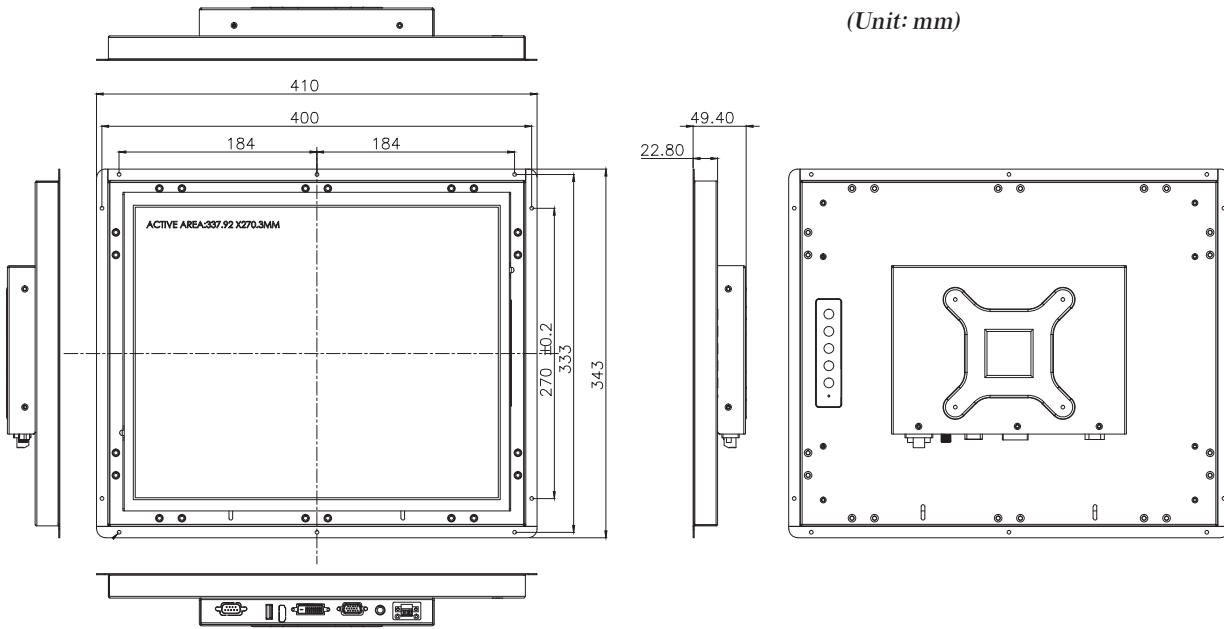

LCD-KIT-F-19A Dimensions
(Unit: mm)

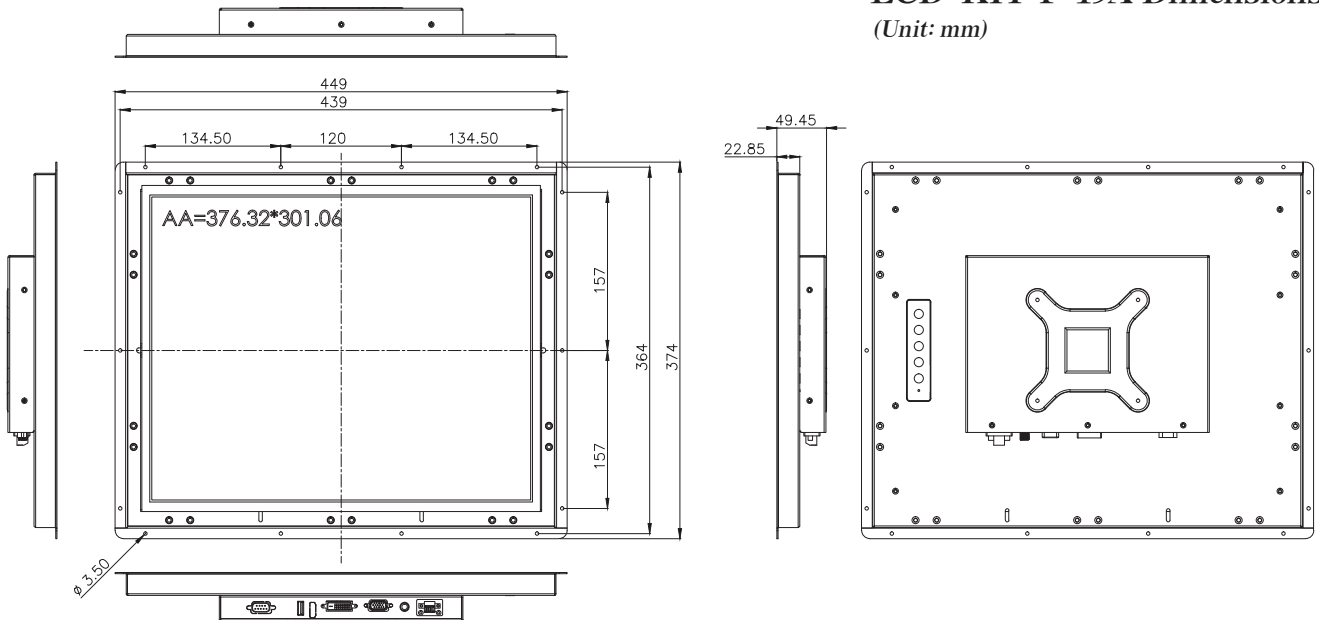

1
Industrial
Computing
Solutions

2
Video
Capture
Solutions

3
Industrial
Computer
Chassis

4
Open
Frame
Monitor

5
Power Supply/
Peripherals

6
All-in-One
System