

**MODEL:  
IMBA-BDE**

**ATX Motherboard with 14nm Intel® Xeon® Processor  
D-1500 Series, DDR4, VGA, Dual Intel® GbE, Four USB 3.0,  
Six SATA 6Gb/s, M.2, Supports Dual 10GbE, RoHS**

# User Manual

# Revision

---

Date	Version	Changes
June 22, 2017	1.00	Initial release

# Copyright

---

## **COPYRIGHT NOTICE**

The information in this document is subject to change without prior notice in order to improve reliability, design and function and does not represent a commitment on the part of the manufacturer.

In no event will the manufacturer be liable for direct, indirect, special, incidental, or consequential damages arising out of the use or inability to use the product or documentation, even if advised of the possibility of such damages.

This document contains proprietary information protected by copyright. All rights are reserved. No part of this manual may be reproduced by any mechanical, electronic, or other means in any form without prior written permission of the manufacturer.

## **TRADEMARKS**

All registered trademarks and product names mentioned herein are used for identification purposes only and may be trademarks and/or registered trademarks of their respective owners.

# Manual Conventions

---



## **WARNING**

Warnings appear where overlooked details may cause damage to the equipment or result in personal injury. Warnings should be taken seriously.



## **CAUTION**

Cautionary messages should be heeded to help reduce the chance of losing data or damaging the product.



## **NOTE**

These messages inform the reader of essential but non-critical information. These messages should be read carefully as any directions or instructions contained therein can help avoid making mistakes.



## **HOT SURFACE**

This symbol indicates a hot surface that should not be touched without taking care.

# Table of Contents

<b>1 INTRODUCTION.....</b>	<b>1</b>
1.1 INTRODUCTION.....	2
1.2 MODEL VARIATIONS .....	3
1.3 FEATURES.....	3
1.4 CONNECTORS .....	4
1.5 DIMENSIONS.....	5
1.6 DATA FLOW .....	6
1.7 TECHNICAL SPECIFICATIONS .....	7
<b>2 PACKING LIST.....</b>	<b>9</b>
2.1 ANTI-STATIC PRECAUTIONS .....	10
2.2 UNPACKING PRECAUTIONS.....	10
2.3 PACKING LIST.....	11
2.4 OPTIONAL ITEMS .....	12
<b>3 CONNECTORS .....</b>	<b>13</b>
3.1 PERIPHERAL INTERFACE CONNECTORS.....	14
3.1.1 <i>Layout</i> .....	14
3.1.2 <i>Peripheral Interface Connectors</i> .....	15
3.1.3 <i>External Interface Panel Connectors</i> .....	16
3.2 INTERNAL PERIPHERAL CONNECTORS .....	17
3.2.1 <i>+12V ATX Power Connector</i> .....	17
3.2.2 <i>10GbE LAN Card Slot</i> .....	18
3.2.3 <i>ATX Power Connector</i> .....	19
3.2.4 <i>Battery Connector</i> .....	20
3.2.5 <i>BMC Debug Connector</i> .....	21
3.2.6 <i>CPLD Flash Connector</i> .....	22
3.2.7 <i>DDR4 DIMM Slots</i> .....	23
3.2.8 <i>Digital I/O Connector</i> .....	24
3.2.9 <i>EC Debug Connector</i> .....	25
3.2.10 <i>Fan Connector (CPU)</i> .....	26

3.2.11 Fan Connector (System).....	27
3.2.12 Front Panel Connector .....	28
3.2.13 PC Connector .....	29
3.2.14 M.2 Slot.....	30
3.2.15 PCIe x4 Slot (Gen 2).....	31
3.2.16 PCIe x4 Slots (Gen 3) .....	32
3.2.17 Power Button .....	33
3.2.18 Reset Button .....	34
3.2.19 SATA 6Gb/s Drive Connectors.....	34
3.2.20 Serial Port Connector, RS-232.....	36
3.2.21 Serial Port Connector, RS-422/485.....	37
3.2.22 SPI Flash Connector (BIOS) .....	38
3.2.23 SPI Flash Connector (BMC).....	39
3.2.24 SPI Flash Connector (EC).....	40
3.2.25 TPM Connector.....	41
3.2.26 USB 2.0 Connectors.....	42
3.2.27 USB 2.0 Connector (Type A).....	43
<b>3.3 EXTERNAL INTERFACE CONNECTORS .....</b>	<b>44</b>
3.3.1 Ethernet and USB 3.0 Connectors .....	44
3.3.2 PS/2 Keyboard and Mouse Connectors .....	45
3.3.3 Serial Port and VGA Connector .....	46
3.3.4 USB 2.0 Connectors.....	47
<b>4 INSTALLATION .....</b>	<b>48</b>
4.1 ANTI-STATIC PRECAUTIONS .....	49
4.2 INSTALLATION CONSIDERATIONS.....	49
4.3 DIMM INSTALLATION .....	51
4.4 M.2 MODULE INSTALLATION.....	52
4.5 SYSTEM CONFIGURATION.....	55
4.5.1 AT/ATX Power Mode Selection.....	55
4.5.2 Clear CMOS Jumpers.....	56
4.6 INTERNAL PERIPHERAL DEVICE CONNECTIONS.....	57
4.6.1 SATA Drive Connection .....	57
4.7 DRIVER INSTALLATION.....	58
<b>5 BIOS.....</b>	<b>60</b>

## IMBA-BDE ATX Motherboard

5.1 INTRODUCTION.....	61
5.1.1 Starting Setup.....	61
5.1.2 Using Setup.....	61
5.1.3 Getting Help.....	62
5.1.4 Unable to Reboot after Configuration Changes.....	62
5.1.5 BIOS Menu Bar.....	62
5.2 MAIN.....	63
5.3 ADVANCED.....	64
5.3.1 Trusted Computing.....	65
5.3.2 F81866 Super IO Configuration.....	66
5.3.2.1 Serial Port n Configuration.....	66
5.3.3 iWDD H/W Monitor.....	73
5.3.3.1 Smart Fan Mode Configuration.....	74
5.3.4 RTC Wake Settings.....	75
5.3.5 Serial Port Console Redirection.....	76
5.3.5.1 Legacy Console Redirection Settings.....	79
5.3.6 USB Configuration.....	80
5.3.7 IEI Feature.....	81
5.4 INTELRCSETUP.....	82
5.4.1 Processor Configuration.....	83
5.4.2 PCH Configuration.....	84
5.4.2.1 PCI Express Configuration.....	84
5.4.2.2 PCH SATA Configuration.....	85
5.5 SECURITY.....	86
5.6 BOOT.....	87
5.7 SAVE & EXIT.....	89
<b>A REGULATORY COMPLIANCE.....</b>	<b>90</b>
<b>B PRODUCT DISPOSAL.....</b>	<b>92</b>
<b>C BIOS OPTIONS.....</b>	<b>94</b>
<b>D TERMINOLOGY.....</b>	<b>97</b>
<b>E DIGITAL I/O INTERFACE.....</b>	<b>101</b>
E.1 INTRODUCTION.....	102
E.2 ASSEMBLY LANGUAGE SAMPLE 1.....	103

E.3 ASSEMBLY LANGUAGE SAMPLE 2 ..... 103

**F HAZARDOUS MATERIALS DISCLOSURE..... 104**



# List of Figures

Figure 1-1: IMBA-BDE .....	2
Figure 1-2: Connectors .....	4
Figure 1-3: IMBA-BDE Dimensions (mm).....	5
Figure 1-4: Data Flow Diagram.....	6
Figure 3-1: Peripheral Interface Connectors .....	14
Figure 3-2: +12V ATX Power Connector Location.....	17
Figure 3-3: 10GbE LAN Card Slot Location .....	18
Figure 3-4: ATX Power Connector Location .....	19
Figure 3-5: Battery Connector Location.....	20
Figure 3-6: BMC Debug Connector Location.....	21
Figure 3-7: CPLD Flash Connector Location.....	22
Figure 3-8: DDR4 DIMM Slot Locations .....	23
Figure 3-9: Digital I/O Connector Location .....	24
Figure 3-10: EC Debug Connector Location.....	25
Figure 3-11: CPU Fan Connector Location .....	26
Figure 3-12: System Fan Connector Location.....	27
Figure 3-13: Front Panel Connector Location .....	28
Figure 3-14: I <sup>2</sup> C Connector Location .....	29
Figure 3-15: M.2 Slot Location .....	30
Figure 3-16: PCIe x4 Slot (Gen 2) Location .....	31
Figure 3-17: PCIe x4 Slot (Gen 3) Locations.....	32
Figure 3-18: Power Button Location.....	33
Figure 3-19: Reset Button Location.....	34
Figure 3-20: SATA 6Gb/s Drive Connector Locations .....	35
Figure 3-21: RS-232 Serial Port Connector Location.....	36
Figure 3-22: RS-422/485 Serial Port Connector Location.....	37
Figure 3-23: BIOS SPI Flash Connector Location .....	38
Figure 3-24: BMC SPI Flash Connector Location.....	39
Figure 3-25: EC SPI Flash Connector Location.....	40
Figure 3-26: TPM Connector Location.....	41

Figure 3-27: USB 2.0 Connector Locations .....	42
Figure 3-28: USB 2.0 Connector (Type A) Pinout Location.....	43
Figure 3-29: External Interface Connectors.....	44
Figure 3-30: PS/2 Keyboard and Mouse Connectors.....	46
Figure 3-31: RS-232 Serial Port Connector Pinouts.....	46
Figure 3-32: VGA Connector .....	47
Figure 4-1: DIMM Installation.....	51
Figure 4-2: Removing the M.2 Module Retention Screw .....	52
Figure 4-3: Inserting the M.2 Module into the Slot at an Angle .....	53
Figure 4-4: Securing the M.2 Module.....	53
Figure 4-5: Removing the M.2 Module Retention Screw and Standoff .....	54
Figure 4-6: Installing the Standoff .....	55
Figure 4-7: AT/ATX Power Mode Switch Location .....	55
Figure 4-8: Clear CMOS Jumper Locations .....	56
Figure 4-9: SATA Drive Cable Connection.....	57
Figure 4-10: SATA Power Drive Connection.....	58

# List of Tables

Table 1-1: Model Variations .....	3
Table 1-2: Technical Specifications.....	8
Table 2-1: Packing List.....	11
Table 2-2: Optional Items .....	12
Table 3-1: Peripheral Interface Connectors .....	16
Table 3-2: Rear Panel Connectors .....	16
Table 3-3: +12V ATX Power Connector Pinouts .....	17
Table 3-4: ATX Power Connector Pinouts .....	19
Table 3-5: BMC Debug Connector Pinouts .....	21
Table 3-6: CPLD Flash Connector Pinouts .....	22
Table 3-7: Digital I/O Connector Pinouts.....	24
Table 3-8: EC Debug Connector Pinouts .....	25
Table 3-9: CPU Fan Connector Pinouts.....	26
Table 3-10: System Fan Connector Pinouts .....	27
Table 3-11: Front Panel Connector Pinouts.....	28
Table 3-12: I <sup>2</sup> C Connector Pinouts.....	29
Table 3-13: SATA 6Gb/s Drive Connector Pinouts.....	35
Table 3-14: RS-232 Serial Port Connector Pinouts .....	37
Table 3-15: RS-422/485 Serial Port Connector Pinouts .....	37
Table 3-16: DB-9 RS-422/485 Pinouts .....	38
Table 3-17: BIOS SPI Flash Connector Pinouts .....	39
Table 3-18: BMC SPI Flash Connector Pinouts .....	40
Table 3-19: EC SPI Flash Connector Pinouts .....	40
Table 3-20: TPM Connector Pinouts .....	41
Table 3-21: USB 2.0 Connector Pinouts.....	42
Table 3-22: USB 2.0 Connector (Type A) Pinouts .....	43
Table 3-23: USB 3.0 Port Pinouts.....	44
Table 3-24: LAN Pinouts .....	45
Table 3-25: PS/2 Keyboard and Mouse Connector Pinouts .....	45
Table 3-26: RS-232 Serial Port Connector Pinouts .....	46

Table 3-27: VGA Connector Pinouts.....	47
Table 3-28: USB 2.0 Port Pinouts.....	47
Table 4-1: AT/ATX Power Mode Switch Settings.....	56
Table 4-2: Clear CMOS Jumper Settings.....	56
Table 5-1: BIOS Navigation Keys.....	62

# BIOS Menus

---

BIOS Menu 1: Main .....	63
BIOS Menu 2: Advanced .....	64
BIOS Menu 3: Trusted Computing .....	65
BIOS Menu 4: F81866 Super IO Configuration .....	66
BIOS Menu 5: Serial Port n Configuration Menu .....	66
BIOS Menu 6: iWDD H/W Monitor .....	73
BIOS Menu 7: Smart Fan Mode Configuration .....	74
BIOS Menu 8: RTC Wake Settings .....	75
BIOS Menu 9: Serial Port Console Redirection .....	77
BIOS Menu 10: Legacy Console Redirection Settings .....	79
BIOS Menu 11: USB Configuration .....	80
BIOS Menu 12: IEI Feature .....	81
BIOS Menu 13: IntelRCSetup.....	82
BIOS Menu 14: Processor Configuration .....	83
BIOS Menu 15: PCH Configuration .....	84
BIOS Menu 16: PCI Express Configuration .....	84
BIOS Menu 17: PCH SATA Configuration .....	85
BIOS Menu 18: Security .....	86
BIOS Menu 19: Boot .....	87
BIOS Menu 20: Save & Exit.....	89

Chapter

1

# Introduction

---

## 1.1 Introduction

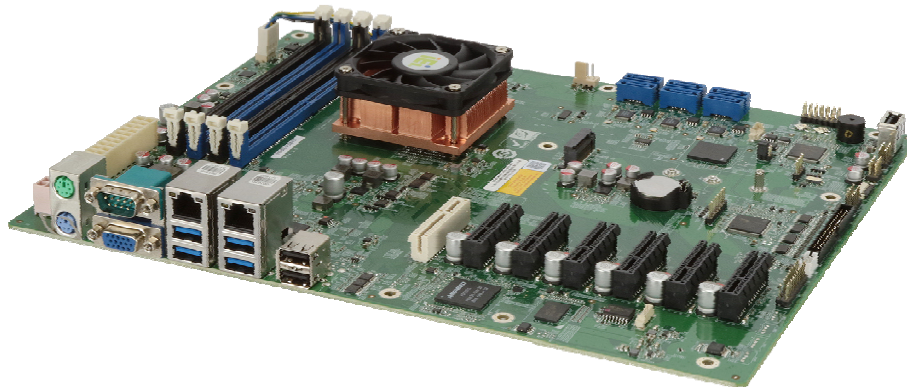

**Figure 1-1: IMBA-BDE**

The IMBA-BDE is an ATX motherboard. It has an on-board 14nm Intel® Xeon® processor D-1500 series, and supports four 288-pin 2133 MHz dual-channel DDR4 DIMM modules up to 128 GB.

The IMBA-BDE equips with two GbE interfaces through the Intel® I210-AT PCIe GbE controllers. In addition, it supports dual 10GbE LAN via the optional 10GbE LAN card. Expansion and I/O include four USB 3.0 and two USB 2.0 on the rear panel, four USB 2.0 by pin header, one USB 2.0 by internal Type A connector, six SATA 6Gb/s, four RS-232, one RS-422/485, one PCIe x4 (Gen 2) slot, five PCIe x4 (Gen 3) slots and one M.2 slot.

## IMBA-BDE ATX Motherboard

### 1.2 Model Variations

The model variations for the IMBA-BDE series are listed in **Table 1-1**.

Model	Processor
IMBA-BDE-1548	Intel® Xeon® D-1548 (up to 8 cores, 12 MB cache, TDP=45W)
IMBA-BDE-1518	Intel® Xeon® D-1518 (up to 4 cores, 6 MB cache, TDP=35 W)

**Table 1-1: Model Variations**

### 1.3 Features

Some of the IMBA-BDE motherboard features are listed below:

- ATX form factor
- On-board 14nm Intel® Xeon® processor D-1500 series
- Four 288-pin 2133 MHz dual-channel ECC unbuffered/registered DDR4 SDRAM DIMMs supported (system max. 128 GB)
- Supports dual 10GbE LAN (via optional 10GbE LAN card)
- Supports PCI Express Generation 3.0 at 8 GT/s I/O bandwidth
- Complete I/O interfaces, including four USB 3.0, seven USB 2.0, five RS-232, one RS-422/485 and six SATA 6Gb/s
- Flexible expansion options, including five PCIe x4 (Gen 3) slots, one PCIe x4 (Gen 2) slot, one M.2 (M key) slot and one 10GbE LAN card slot
- RoHS compliant



## 1.4 Connectors

The connectors on the IMBA-BDE are shown in the following figures.

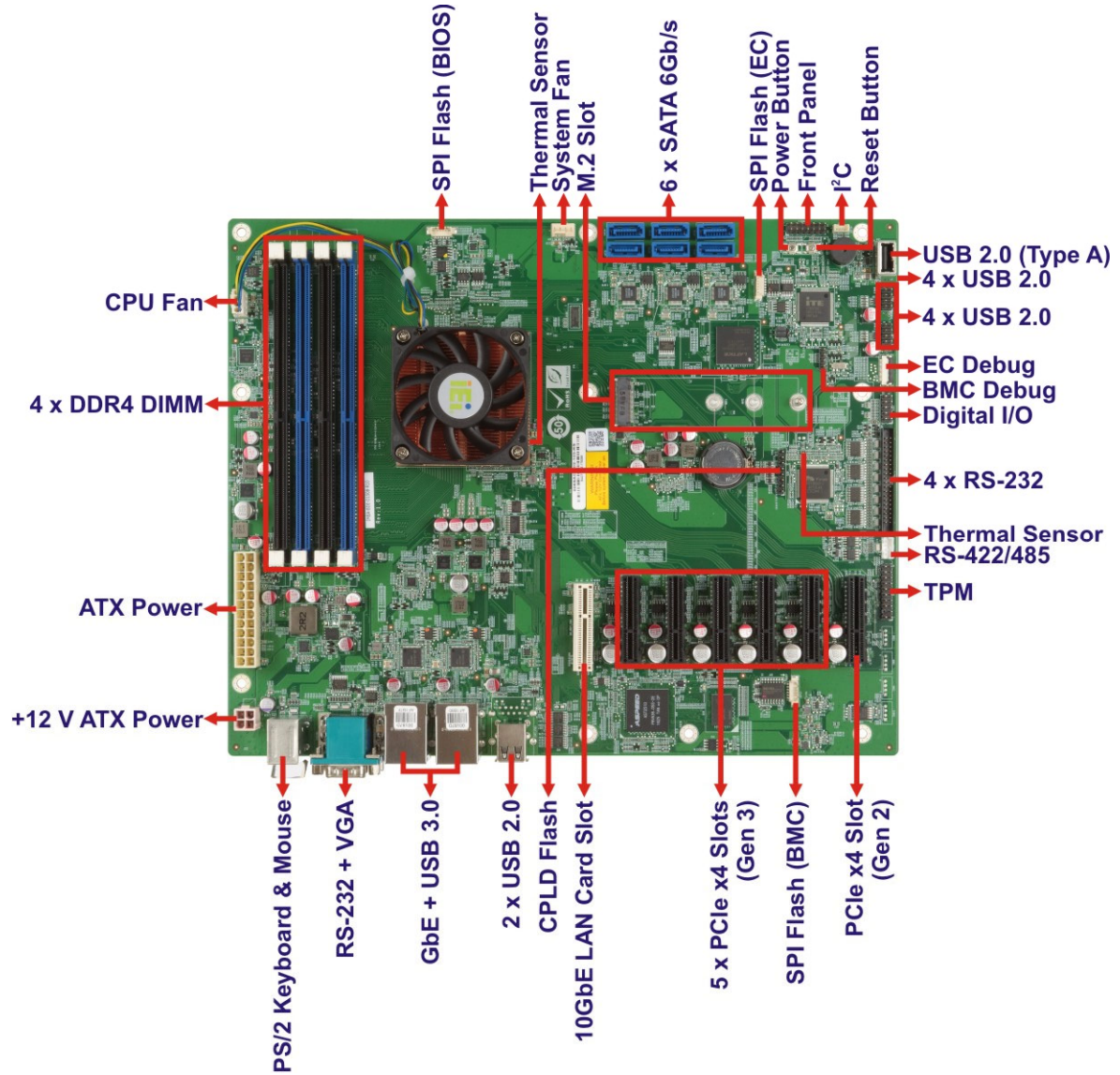

Figure 1-2: Connectors

IMBA-BDE ATX Motherboard

1.5 Dimensions

The main dimensions of the IMBA-BDE are shown in the diagram below.

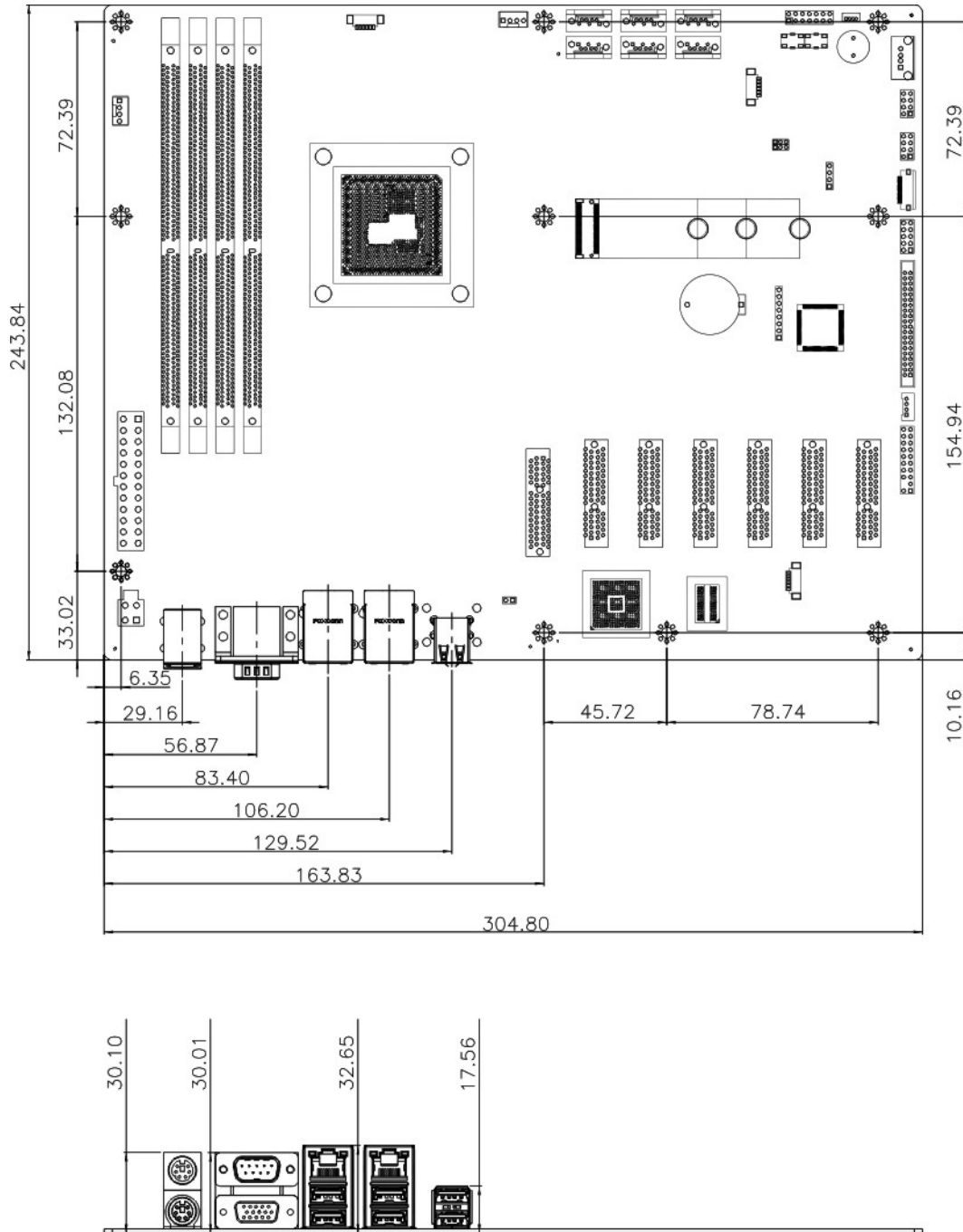

Figure 1-3: IMBA-BDE Dimensions (mm)

**1.6 Data Flow**

Figure 1-4 shows the data flow between the system chipset, the SoC and other components installed on the motherboard.

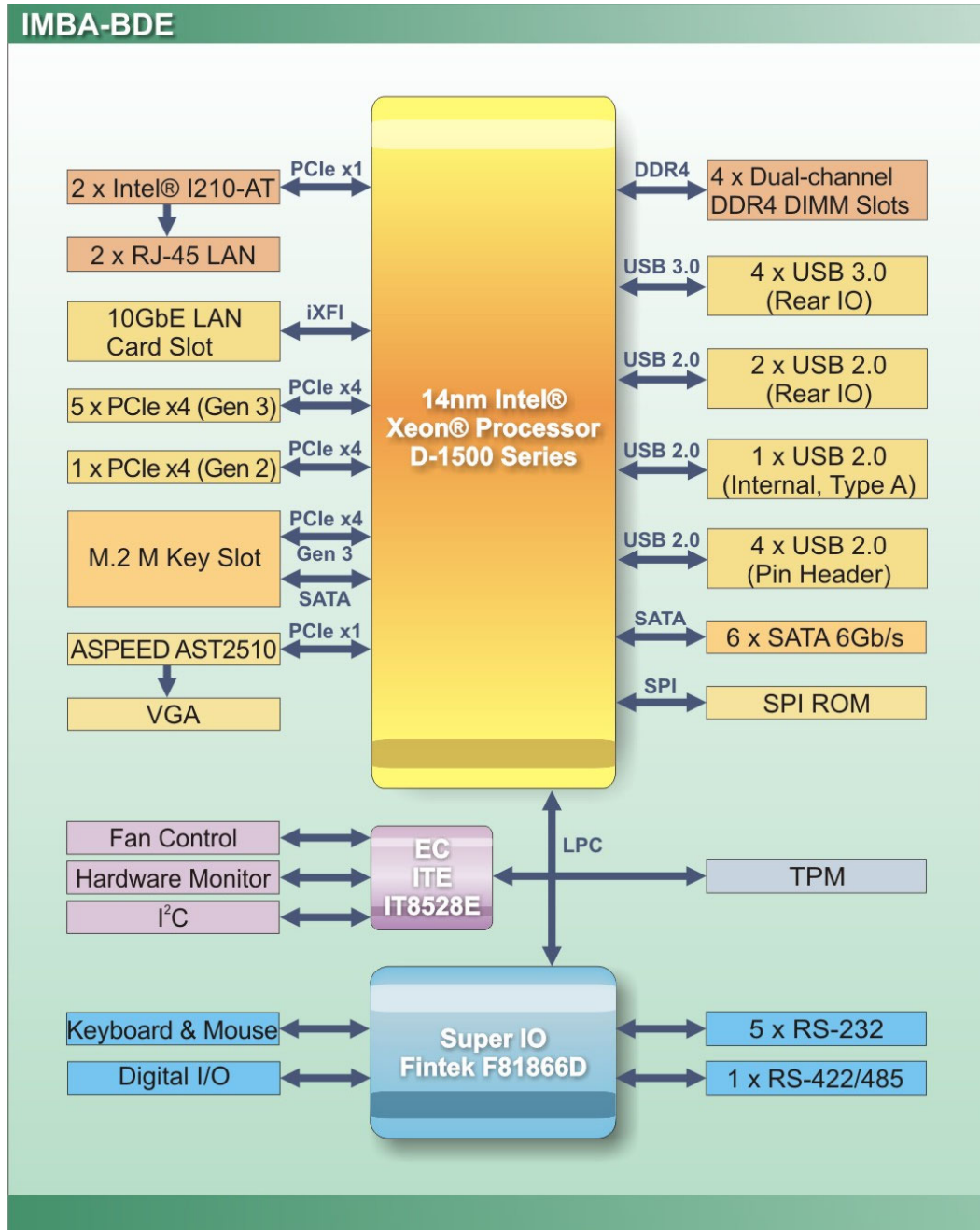

Figure 1-4: Data Flow Diagram

## IMBA-BDE ATX Motherboard

### 1.7 Technical Specifications

The IMBA-BDE technical specifications are listed in **Table 1-2**.

Specifications/Model	IMBA-BDE
<b>Form Factor</b>	ATX
<b>CPU</b>	Intel® Xeon® processor D-1548 (up to 8 cores, 12 MB cache, TDP=45 W) Intel® Xeon® processor D-1518 (up to 4 cores, 6 MB cache, TDP=35 W)
<b>Memory</b>	Four 288-pin 2133 MHz dual-channel ECC unbuffered/registered DDR4 SDRAM DIMMs supported (system max. 128 GB)
<b>Ethernet</b>	<b>LAN1 &amp; LAN2:</b> Intel® I210-AT PCIe GbE controller <b>LAN3 &amp; LAN4 (optional):</b> Inphi CS4227 PHY
<b>Display Output</b>	One VGA (up to 1920x1200@60 Hz)
<b>BIOS</b>	AMI BIOS
<b>Super I/O Controller</b>	Fintek F81866D
<b>Watchdog Timer</b>	Software programmable, supports 1~255 sec. system reset
<b>Expansions</b>	One 10GbE LAN card slot 1 x M.2 slot (M key, 2242 ~ 2280, SATA and PCIe signal) One PCIe x4 slot (Gen 2) Five PCIe x4 slots (Gen 3)
<b>I/O Interfaces</b>	
<b>Digital I/O</b>	One 8-bit digital I/O
<b>Ethernet</b>	Two RJ-45 GbE ports
<b>Fan</b>	One 4-pin CPU smart fan connector One 4-pin system smart fan connector
<b>Front Panel</b>	One 14-pin header (power LED, HDD LED, speaker, power button, reset button)

<b>I<sup>2</sup>C</b>	One 4-pin wafer connector
<b>Keyboard and Mouse</b>	One PS/2 keyboard connector One PS/2 mouse connector
<b>LAN LEDs</b>	Two 2-pin headers
<b>Serial ATA</b>	Six SATA 6Gb/s connectors (support RAID 0, 1, 5, 10)
<b>Serial Ports</b>	One RS-232 (DB-9) one rear panel Four RS-232 by internal 40-pin headers One RS-422/485 by internal 4-pin wafer connector
<b>SMBus</b>	One 4-pin wafer connector
<b>TPM</b>	One 20-pin header
<b>USB 2.0</b>	One USB 2.0 port by internal Type A connector Two USB 2.0 ports on rear panel Four USB 2.0 ports via internal pin header
<b>USB 3.0</b>	Four USB 3.0 ports on rear panel
<b>Environmental and Power Specifications</b>	
<b>Power Supply</b>	ATX power supply Supports AT/ATX mode
<b>Power Consumption</b>	3.3V@0.11A, 5V@2.83A, 12V@3.97A (Intel® Xeon® D-1548 CPU with four 8 GB 2133 MHz DDR4 memory)
<b>Operating Temperature</b>	0°C ~ 60°C
<b>Storage Temperature</b>	-10°C ~ 70°C
<b>Operating Humidity</b>	5% ~ 95% (non-condensing)
<b>Physical Specifications</b>	
<b>Dimensions</b>	244 mm x 305 mm
<b>Weight (GW/NW)</b>	1200 g/700 g

**Table 1-2: Technical Specifications**

Chapter

**2**

# Packing List

---

## 2.1 Anti-static Precautions

---



### WARNING!

Static electricity can destroy certain electronics. Make sure to follow the ESD precautions to prevent damage to the product, and injury to the user.

---

Make sure to adhere to the following guidelines:

- **Wear an anti-static wristband:** Wearing an anti-static wristband can prevent electrostatic discharge.
- **Self-grounding:** Touch a grounded conductor every few minutes to discharge any excess static buildup.
- **Use an anti-static pad:** When configuring any circuit board, place it on an anti-static mat.
- **Only handle the edges of the PCB:** Don't touch the surface of the motherboard. Hold the motherboard by the edges when handling.

## 2.2 Unpacking Precautions

When the IMBA-BDE is unpacked, please do the following:

- Follow the anti-static guidelines above.
- Make sure the packing box is facing upwards when opening.
- Make sure all the packing list items are present.

## IMBA-BDE ATX Motherboard

### 2.3 Packing List



#### NOTE:

If any of the components listed in the checklist below are missing, do not proceed with the installation. Contact the IEI reseller or vendor the IMBA-BDE was purchased from or contact an IEI sales representative directly by sending an email to [sales@ieiworld.com](mailto:sales@ieiworld.com).

The IMBA-BDE is shipped with the following components:









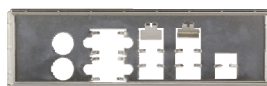

Quantity	Item and Part Number	Image
1	IMBA-BDE single board computer	
2	SATA cable	
1	I/O shielding	
1	Utility CD	
1	One Key Recovery CD	
1	Quick installation guide	

Table 2-1: Packing List

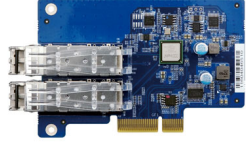

## 2.4 Optional Items

The following are optional components which may be separately purchased:

Item and Part Number	Image
Dual-port 10GbE LAN card (P/N: LAN-10G2F-PHY-CS4227)	
Dual-port USB cable with bracket, 300 mm, P=2.54 (P/N: 19800-003100-100-RS)	
SATA power cable (P/N: 32102-000100-200-RS)	
RS-422/485 cable, 200 mm, P=2.00 (P/N: 32205-003800-300-RS)	
20-pin Infineon TPM module, software management tool, firmware v4.4 (P/N: TPM-IN01-R20)	

**Table 2-2: Optional Items**

Chapter

**3**

# Connectors

---

### 3.1 Peripheral Interface Connectors

This chapter details all the peripheral interface connectors.

#### 3.1.1 Layout

The figures below show all the peripheral interface connectors.

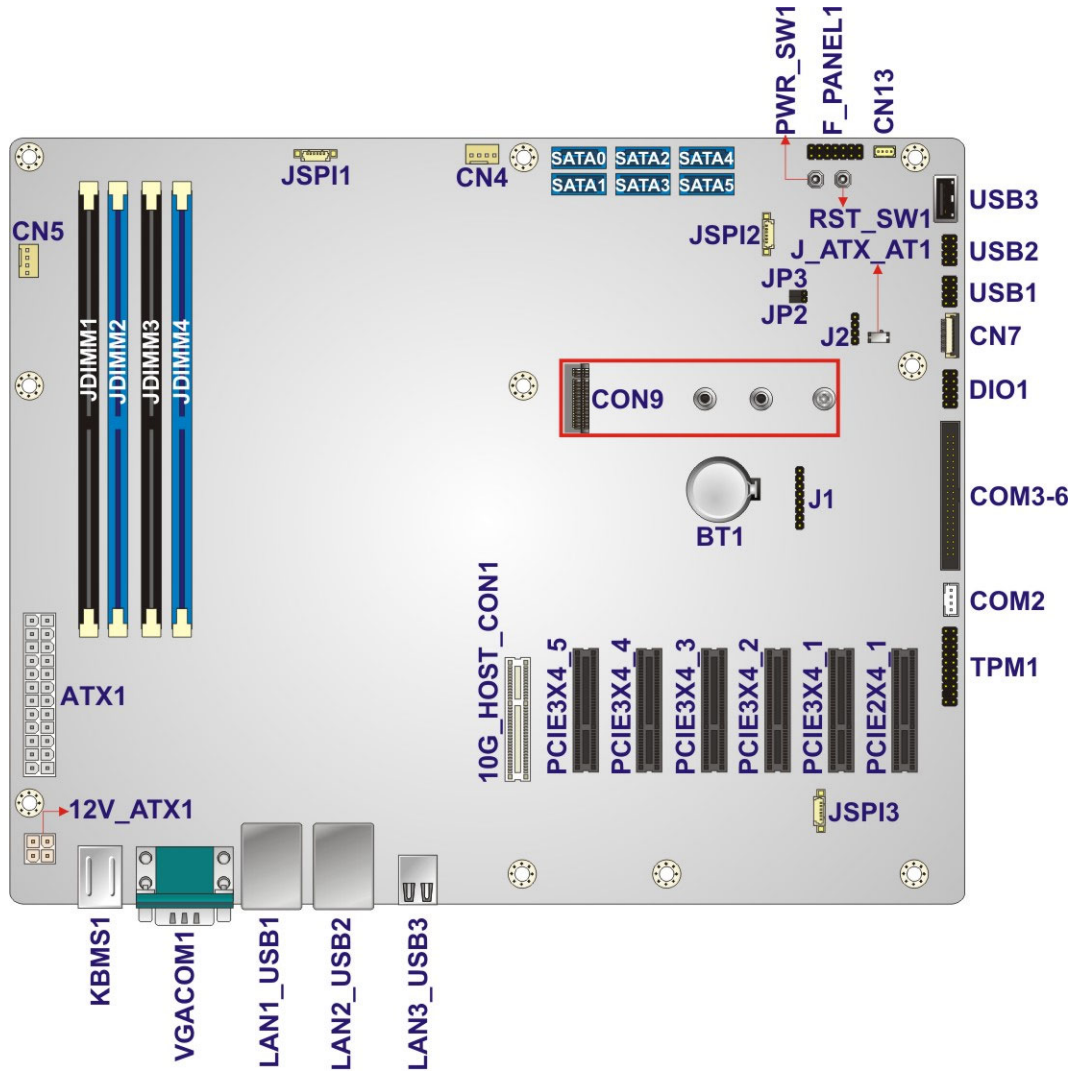

Figure 3-1: Peripheral Interface Connectors

## IMBA-BDE ATX Motherboard

### 3.1.2 Peripheral Interface Connectors

The table below lists all the connectors on the board.

Connector	Type	Label
+12V ATX power connector	4-pin Molex power connector	12V_ATX1
10GbE LAN card slot	10GbE LAN card slot	10G_HOST_CON1
ATX power connector	24-pin connector	ATX1
Battery connector	Battery holder	BT1
BMC debug connector	4-pin header	J2
CPLD flash connector	8-pin header	J1
DDR4 DIMM sockets	288-pin socket	JDIMM1, JDIMM2, JDIMM3, JDIMM4
Digital I/O connector	10-pin header	DIO1
EC debug connector	20-pin wafer	CN7
Fan connector (CPU)	4-pin wafer	CN5
Fan connector (system)	4-pin wafer	CN4
Front panel connector	14-pin header	F_PANEL1
I <sup>2</sup> C connector	4-pin wafer	CN13
M.2 slot	M.2 2242 ~ 2280 slot, M key	CON9
PCIe x4 slot (Gen 2)	PCIe x4 slot, Gen 2	PCIE2X4_1
PCIe x4 slots (Gen 3)	PCIe x4 slot, Gen 3	PCIE3X4_1, PCIE3X4_2, PCIE3X4_3, PCIE3X4_4, PCIE3X4_5,
Power button	Push button	PWR_SW1
Reset button	Push button	RST_SW1

Connector	Type	Label
SATA 6Gb/s connectors	7-pin SATA connector	SATA0, SATA1, SATA2, SATA3, SATA4, SATA5
Serial port, RS-232	40-pin box header	COM3-6
Serial port, RS-422/485	4-pin wafer	COM2
SPI flash connector (BIOS)	6-pin wafer	JSPI1
SPI flash connector (BMC)	6-pin wafer	JSPI3
SPI flash connector (EC)	6-pin wafer	JSPI2
TPM connector	20-pin header	TPM1
USB 2.0 connectors	8-pin header	USB1, USB2
USB 2.0 connector (Type A)	USB 2.0, Type A	USB3

**Table 3-1: Peripheral Interface Connectors**

### 3.1.3 External Interface Panel Connectors

The table below lists the connectors on the external I/O panel.

Connector	Type	Label
Ethernet and USB 3.0 ports	RJ-45, USB 3.0	LAN1_USB1, LAN2_USB2
Keyboard and mouse connectors	PS/2	KBMS1
RS-232 and VGA connectors	9-pin male DB-9, 15-pin female	VGACOM1
USB 2.0 connectors	USB 2.0	LAN3_USB3

**Table 3-2: Rear Panel Connectors**

## IMBA-BDE ATX Motherboard

### 3.2 Internal Peripheral Connectors

The section describes all of the connectors on the IMBA-BDE.

#### 3.2.1 +12V ATX Power Connector

- CN Label:** 12V\_ATX1
- CN Type:** 4-pin Molex power connector, p=4.2 mm
- CN Location:** See **Figure 3-2**
- CN Pinouts:** See **Table 3-3**

This connector provides power to the CPU.

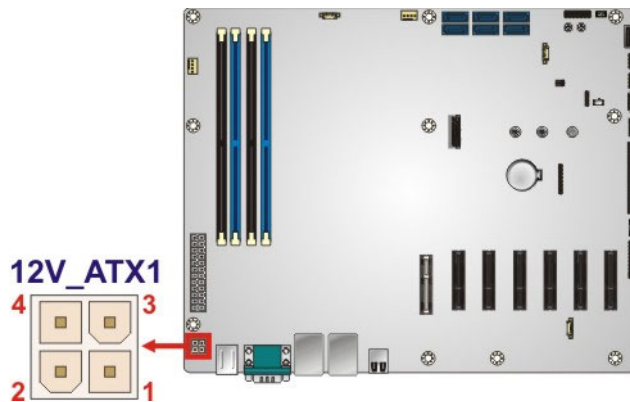

**Figure 3-2: +12V ATX Power Connector Location**

Pin	Description	Pin	Description
1	GND	2	GND
3	+12V	4	+12V

**Table 3-3: +12V ATX Power Connector Pinouts**

### 3.2.2 10GbE LAN Card Slot

- CN Label:** 10G\_HOST\_CON1
- CN Type:** 10GbE LAN card slot
- CN Location:** See **Figure 3-3**

This slot is designed to install the optional 10GbE LAN card.

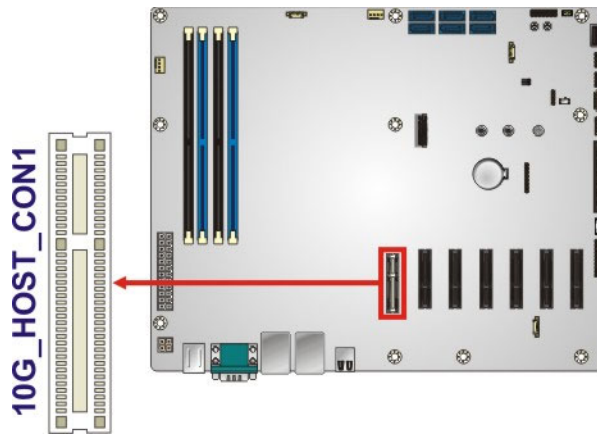

**Figure 3-3: 10GbE LAN Card Slot Location**

## IMBA-BDE ATX Motherboard

### 3.2.3 ATX Power Connector

- CN Label:** ATX1
- CN Type:** 24-pin connector, p=4.2 mm
- CN Location:** See **Figure 3-4**
- CN Pinouts:** See **Table 3-4**

The ATX power connector connects to an ATX power supply.

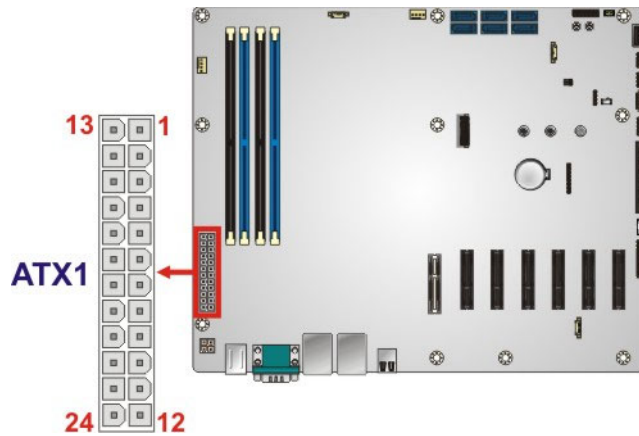

**Figure 3-4: ATX Power Connector Location**

Pin	Description	Pin	Description
1	+3.3V	13	+3.3V
2	+3.3V	14	-12V
3	GND	15	GND
4	+5V	16	PS_ON
5	GND	17	GND
6	+5V	18	GND
7	GND	19	GND
8	Power good	20	-5V
9	5VSB	21	+5V
10	+12V	22	+5V
11	+12V	23	+5V
12	+3.3V	24	GND

**Table 3-4: ATX Power Connector Pinouts**



### 3.2.4 Battery Connector

**CAUTION:**

Risk of explosion if battery is replaced by an incorrect type. Only certified engineers should replace the on-board battery.

Dispose of used batteries according to instructions and local regulations.

- CN Label:** BT1
- CN Type:** Battery holder
- CN Location:** See **Figure 3-5**

A system battery is placed in the battery holder. The battery provides power to the system clock to retain the time when power is turned off.

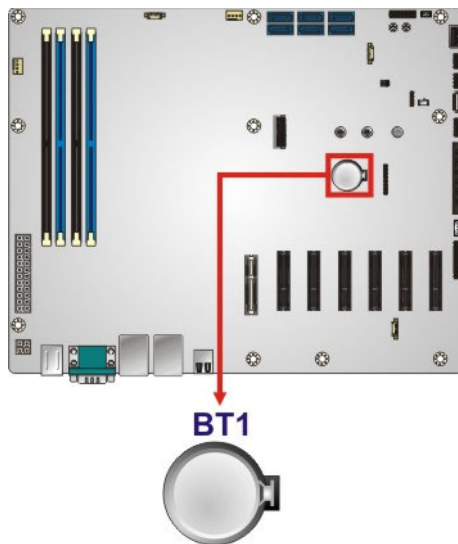

**Figure 3-5: Battery Connector Location**

## IMBA-BDE ATX Motherboard

### 3.2.5 BMC Debug Connector

- CN Label:** J2
- CN Type:** 4-pin header, p=2.54 mm
- CN Location:** See **Figure 3-6**
- CN Pinouts:** See **Table 3-5**

The BMC debug connector is used for debug of the BMC chip.

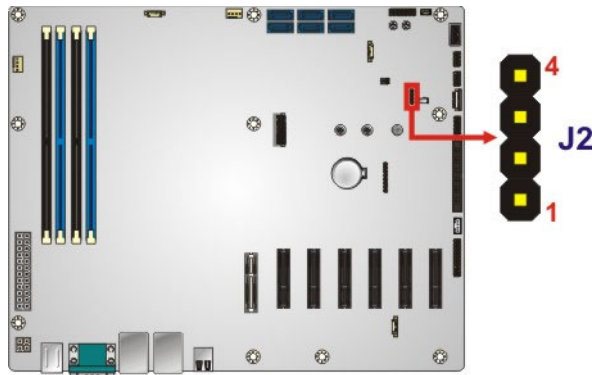

**Figure 3-6: BMC Debug Connector Location**

Pin	Description
1	3.3V
2	EC_SMB_CLK
3	EC_SMB_DAT
4	GND

**Table 3-5: BMC Debug Connector Pinouts**

**3.2.6 CPLD Flash Connector**

- CN Label:** J1
- CN Type:** 8-pin header, p=2.54 mm
- CN Location:** See **Figure 3-7**
- CN Pinouts:** See **Table 3-6**

The CPLD flash connector is used to flash the CPLD.

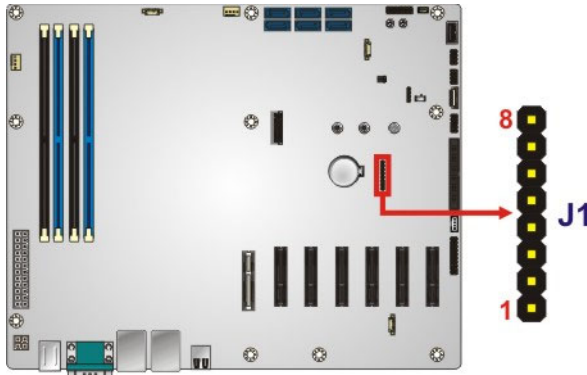

**Figure 3-7: CPLD Flash Connector Location**

Pin	Description
1	3.3V
2	CPLD_TDO
3	CPLD_TDI
4	NC
5	NC
6	CPLD_TMS
7	GND
8	CPLD_TCK

**Table 3-6: CPLD Flash Connector Pinouts**

## IMBA-BDE ATX Motherboard

### 3.2.7 DDR4 DIMM Slots

**CN Label:** JDIMM1, JDIMM2, JDIMM3, JDIMM4

**CN Type:** DDR4 DIMM slot

**CN Location:** See **Figure 3-8**

The DIMM slots are for DDR4 DIMM memory modules.

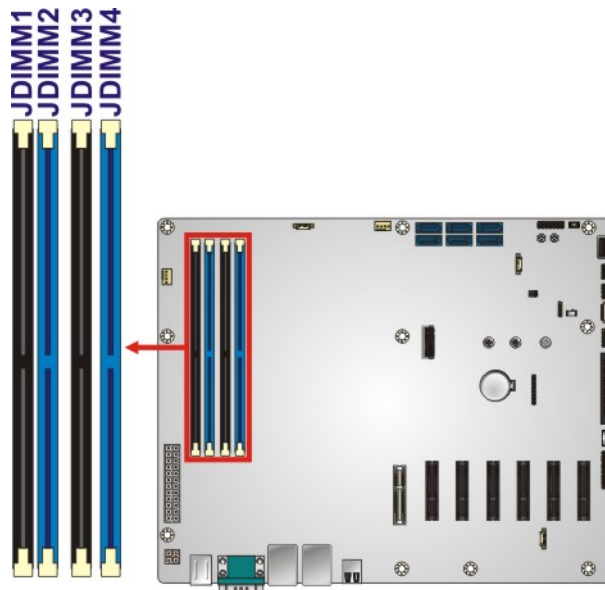
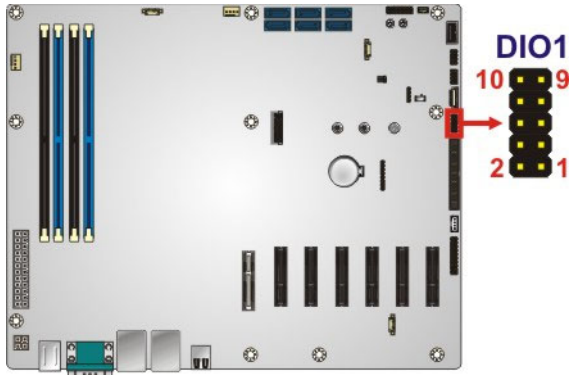

**Figure 3-8: DDR4 DIMM Slot Locations**

**3.2.8 Digital I/O Connector**

- CN Label:** DIO1
- CN Type:** 10-pin header, p=2.54 mm
- CN Location:** See **Figure 3-9**
- CN Pinouts:** See **Table 3-7**

The digital I/O connector provides programmable input and output for external devices.



**Figure 3-9: Digital I/O Connector Location**

Pin	Description	Pin	Description
1	GND	2	+V5S
3	DOUT4	4	DOUT3
5	DOUT2	6	DOUT1
7	DIN4	8	DIN3
9	DIN2	10	DIN1

**Table 3-7: Digital I/O Connector Pinouts**

## IMBA-BDE ATX Motherboard

### 3.2.9 EC Debug Connector

- CN Label:** CN7
- CN Type:** 20-pin wafer, p=0.5 mm
- CN Location:** See **Figure 3-10**
- CN Pinouts:** See **Table 3-8**

The EC debug connector is used for EC debug.

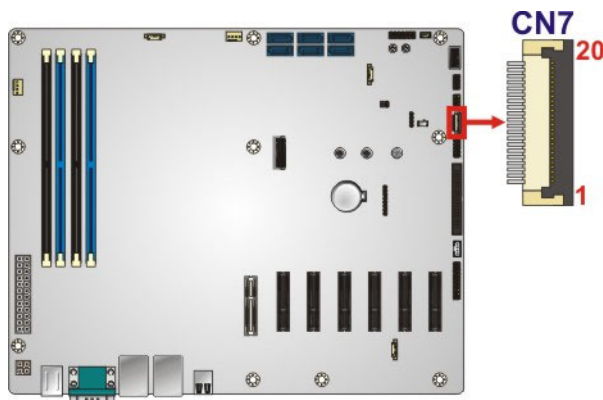

**Figure 3-10: EC Debug Connector Location**

Pin	Description	Pin	Description
1	KS10	11	KSO9
2	KSO0	12	KSO10
3	KSO1	13	KSO12
4	KSO2	14	KS11
5	KSO3	15	KSO11
6	KSO4	16	KS12
7	KSO5	17	KS13
8	KSO6	18	GND
9	KSO7	19	GND
10	KSO8	20	GND

**Table 3-8: EC Debug Connector Pinouts**

### 3.2.10 Fan Connector (CPU)

- CN Label:** CN5
- CN Type:** 4-pin wafer, p=2.54 mm
- CN Location:** See **Figure 3-11**
- CN Pinouts:** See **Table 3-9**

The fan connector attaches to a CPU cooling fan.

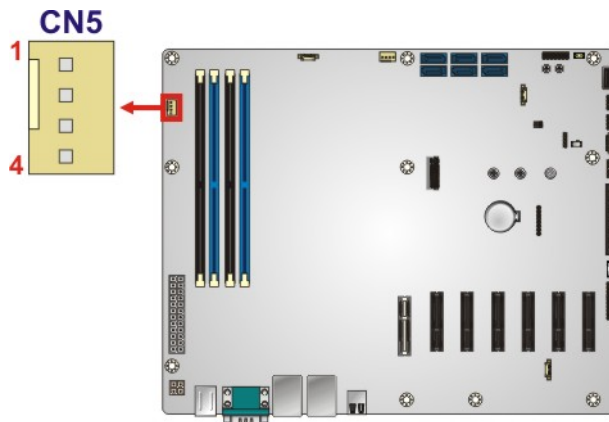

**Figure 3-11: CPU Fan Connector Location**

Pin	Description
1	GND
2	+V12S
3	Rotation signal
4	PWM control signal

**Table 3-9: CPU Fan Connector Pinouts**

## IMBA-BDE ATX Motherboard

### 3.2.11 Fan Connector (System)

- CN Label:** CN4
- CN Type:** 4-pin wafer, p=2.54 mm
- CN Location:** See **Figure 3-12**
- CN Pinouts:** See **Table 3-10**

The fan connector attaches to a CPU cooling fan.

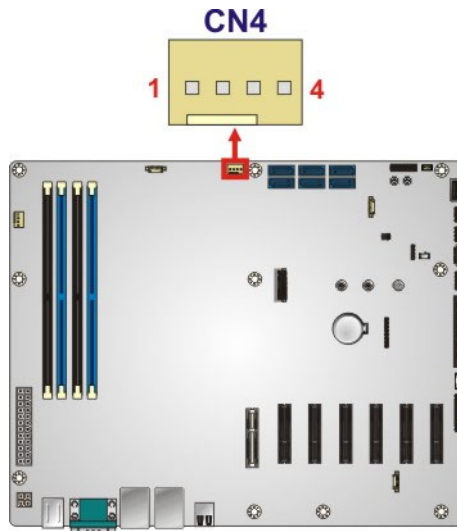

**Figure 3-12: System Fan Connector Location**

Pin	Description
1	GND
2	+V12S
3	Rotation signal
4	PWM control signal

**Table 3-10: System Fan Connector Pinouts**



**3.2.12 Front Panel Connector**

- CN Label:** F\_PANEL1
- CN Type:** 14-pin header, p=2.54 mm
- CN Location:** See **Figure 3-13**
- CN Pinouts:** See **Table 3-11**

The front panel connector connects to the indicator LEDs and buttons on the computer's front panel.

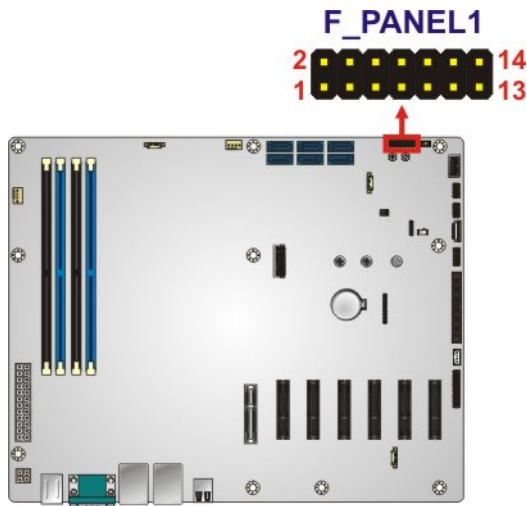

**Figure 3-13: Front Panel Connector Location**

Pin	Description	Pin	Description
1	LED_PWR	2	BEEP_PWR
3	NC	4	NC
5	GND	6	NC
7	PWR_BTN	8	PC_BEEP#
9	GND	10	NC
11	SATA_LED+	12	RESET
13	SATA_LED-	14	GND

**Table 3-11: Front Panel Connector Pinouts**

## IMBA-BDE ATX Motherboard

### 3.2.13 I<sup>2</sup>C Connector

- CN Label:** CN13
- CN Type:** 4-pin wafer, p=1.25 mm
- CN Location:** See **Figure 3-14**
- CN Pinouts:** See **Table 3-12**

The I<sup>2</sup>C connector is used to connect I<sup>2</sup>C-bus devices to the motherboard.

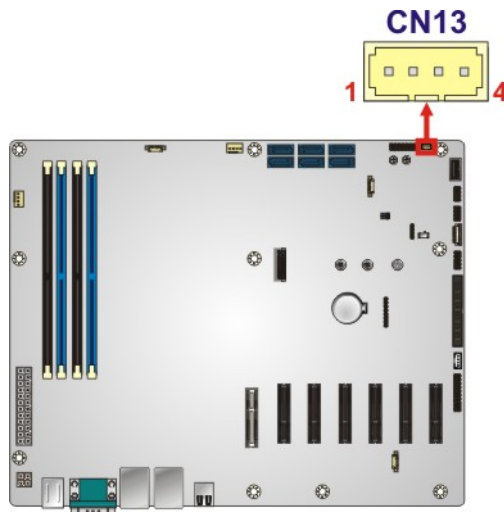

**Figure 3-14: I<sup>2</sup>C Connector Location**

Pin	Description
1	GND
2	SMB_DATA
3	SMB_CLK
4	+5V

**Table 3-12: I<sup>2</sup>C Connector Pinouts**

### 3.2.14 M.2 Slot

<b>CN Label:</b>	<b>CON9</b>
<b>CN Type:</b>	M.2 M key slot
<b>CN Location:</b>	See <b>Figure 3-15</b>

The M.2 slot is keyed in the M position and provides the mounting screw position for 2242/2260/2280-size M.2 module. The M.2 slot supports the signals of SATA and PCIe.

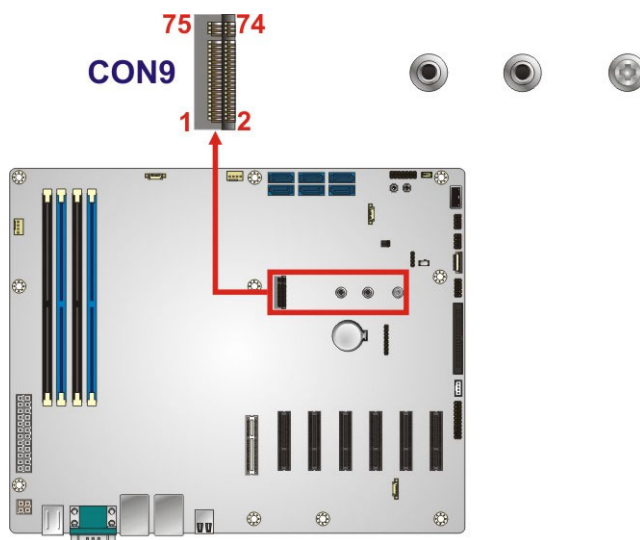

**Figure 3-15: M.2 Slot Location**



#### **NOTE:**

If the SATA signal of the M.2 slot (**CON9**) is being used, such as an M.2 SSD is installed to the M.2 slot, the **SATA5** connector will be disabled.

## IMBA-BDE ATX Motherboard

### 3.2.15 PCIe x4 Slot (Gen 2)

- CN Label:** PCIE2X4\_1  
**CN Type:** PCIe x4 slot, Gen 2  
**CN Location:** See **Figure 3-16**

The PCIe x4 expansion card slot supports PCIe x4, Gen 2 expansion card.

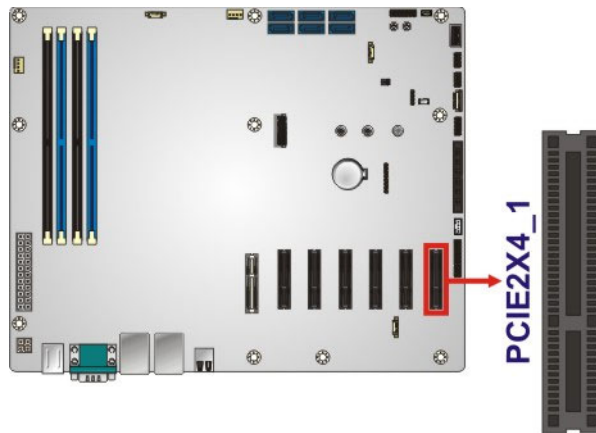

**Figure 3-16: PCIe x4 Slot (Gen 2) Location**

### 3.2.16 PCIe x4 Slots (Gen 3)

**CN Label:** PCIE3X4\_1, PCIE3X4\_2, PCIE3X4\_3, PCIE3X4\_4, PCIE3X4\_5

**CN Type:** PCIe x4 slot, Gen 3

**CN Location:** See **Figure 3-17**

The PCIe x4 expansion card slots support PCIe x4, Gen 3 expansion cards.

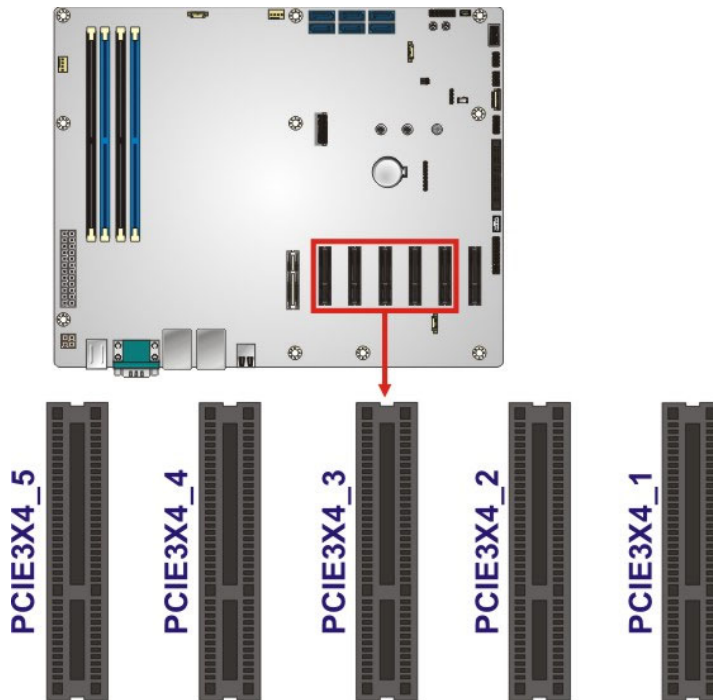

**Figure 3-17: PCIe x4 Slot (Gen 3) Locations**

## IMBA-BDE ATX Motherboard

### 3.2.17 Power Button

- CN Label:** PWR\_SW1  
**CN Type:** Push button  
**CN Location:** See **Figure 3-18**

Push the on-board power button to power on the IMBA-BDE.

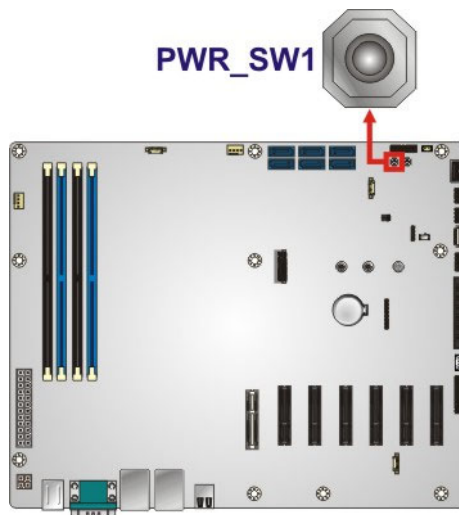
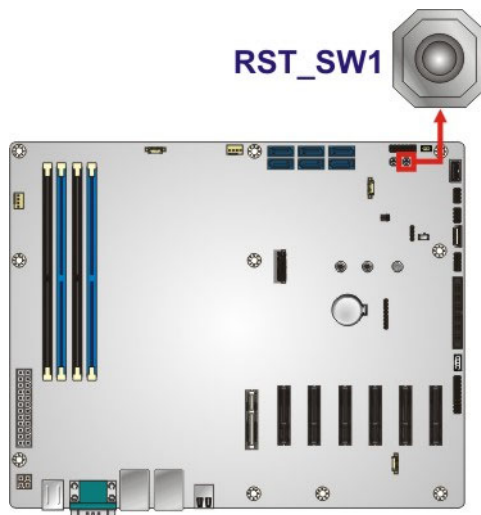

**Figure 3-18: Power Button Location**

### 3.2.18 Reset Button

<b>CN Label:</b>	<b>RST_SW1</b>
<b>CN Type:</b>	Push button
<b>CN Location:</b>	See <b>Figure 3-19</b>

Push the on-board reset button to reboot the IMBA-BDE.



**Figure 3-19: Reset Button Location**

### 3.2.19 SATA 6Gb/s Drive Connectors

<b>CN Label:</b>	<b>SATA0, SATA1, SATA2, SATA3, SATA4, SATA5</b>
<b>CN Type:</b>	7-pin SATA connector
<b>CN Location:</b>	See <b>Figure 3-20</b>
<b>CN Pinouts:</b>	See <b>Table 3-13</b>

The SATA drive connectors can be connected to SATA drives and support up to 6Gb/s data transfer rate.

## IMBA-BDE ATX Motherboard



### NOTE:

If the SATA signal of the M.2 slot (**CON9**) is being used, such as an M.2 SSD is installed to the M.2 slot, the **SATA5** connector will be disabled.

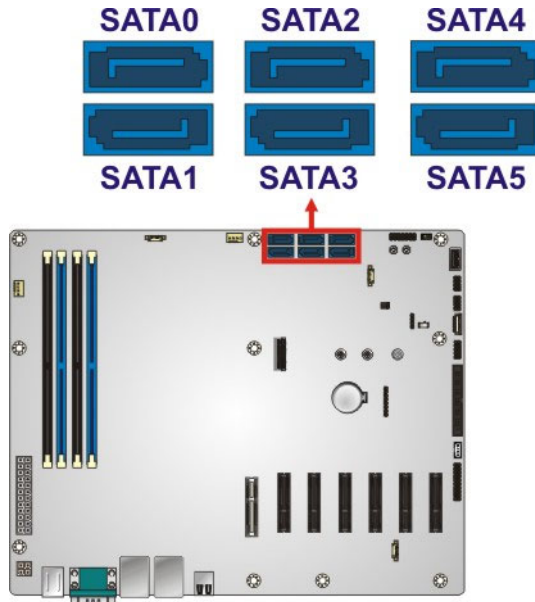

Figure 3-20: SATA 6Gb/s Drive Connector Locations

Pin	Description
1	GND
2	SATA_TX+
3	SATA_TX-
4	GND
5	SATA_RX-
6	SATA_RX+
7	GND

Table 3-13: SATA 6Gb/s Drive Connector Pinouts



**3.2.20 Serial Port Connector, RS-232**

- CN Label:** COM3-6
- CN Type:** 40-pin box header, p=2 mm
- CN Location:** See **Figure 3-21**
- CN Pinouts:** See **Table 3-14**

The 40-pin serial port connector provides four RS-232 serial communications channels.

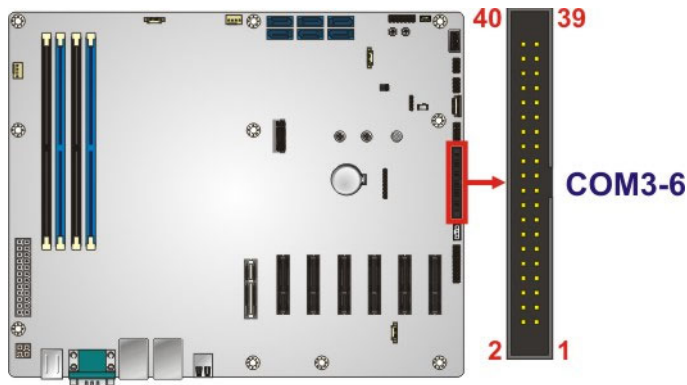

**Figure 3-21: RS-232 Serial Port Connector Location**

Pin	Description	Pin	Description
1	NDCD3#	2	NDSR3#
3	NRXD3	4	NRTS3#
5	NTXD3	6	NCTS3#
7	NDTR3#	8	NR13#
9	GND	10	GND
11	NDCD4#	12	NDSR4#
13	NRXD4	14	NRTS4#
15	NTXD4	16	NCTS4#
17	NDTR4#	18	NR14#
19	GND	20	GND
21	NDCD5#	22	NDSR5#
23	NRXD5	24	NRTS5#
25	NTXD5	26	NCTS5#
27	NDTR5#	28	NR15#

## IMBA-BDE ATX Motherboard

Pin	Description	Pin	Description
29	GND	30	GND
31	NDCD6#	32	NDSR6#
33	NRXD6	34	NRTS6#
35	NTXD6	36	NCTS6#
37	NDTR6#	38	NRI6#
39	GND	40	GND

**Table 3-14: RS-232 Serial Port Connector Pinouts**

### 3.2.21 Serial Port Connector, RS-422/485

- CN Label:** COM2
- CN Type:** 4-pin wafer, p=2 mm
- CN Location:** See **Figure 3-22**
- CN Pinouts:** See **Table 3-15**

This connector provides RS-422 or RS-485 communications.

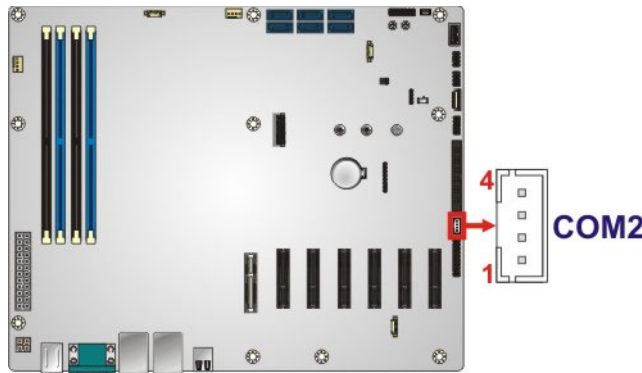

**Figure 3-22: RS-422/485 Serial Port Connector Location**

Pin	Description
1	RXD422-
2	RXD422+
3	TXD422+/TXD485+
4	TXD422-/TXD485-

**Table 3-15: RS-422/485 Serial Port Connector Pinouts**

Use the optional RS-422/485 cable to connect to a serial device. The pinouts of the DB-9 connector are listed below.

RS-422 Pinouts	RS-485 Pinouts

**Table 3-16: DB-9 RS-422/485 Pinouts**

### 3.2.22 SPI Flash Connector (BIOS)

- CN Label:** JSPI1
- CN Type:** 6-pin wafer, p=1.25 mm
- CN Location:** See **Figure 3-23**
- CN Pinouts:** See **Table 3-17**

The SPI flash connector is used to flash the BIOS ROM.

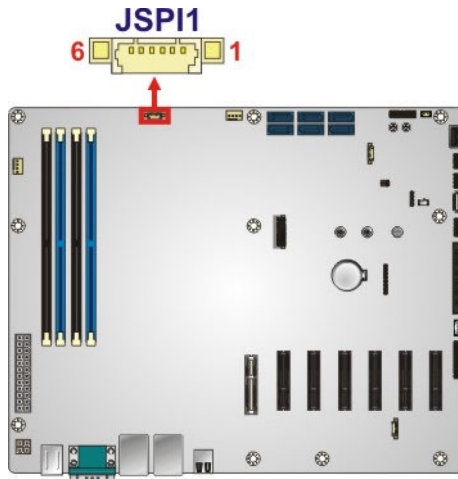

**Figure 3-23: BIOS SPI Flash Connector Location**

## IMBA-BDE ATX Motherboard

Pin	Description
1	+3.3V_BIOS
2	FLASH_SPI_CS0#
3	FLASH_SPI_MISO
4	FLASH_SPI_CLK
5	FLASH_SPI_MOSI
6	GND

**Table 3-17: BIOS SPI Flash Connector Pinouts**

### 3.2.23 SPI Flash Connector (BMC)

- CN Label:** JSPI3
- CN Type:** 6-pin wafer, p=1.25 mm
- CN Location:** See **Figure 3-24**
- CN Pinouts:** See **Table 3-18**

The SPI flash connector is used to flash the BMC ROM.

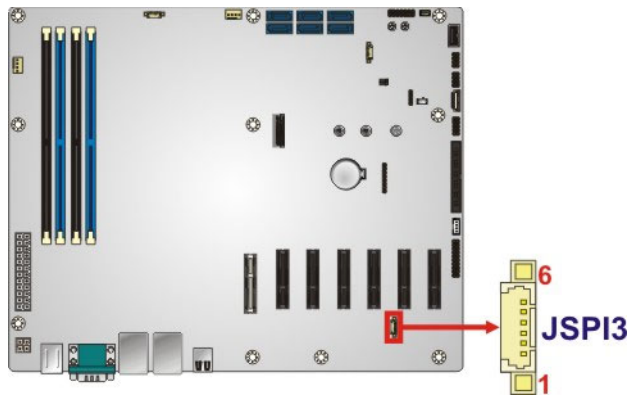

**Figure 3-24: BMC SPI Flash Connector Location**

Pin	Description
1	BMC_SPI_VCC
2	SPI_CS#0_CN
3	SPI_S00_CN
4	SPI_CLK0_CN

Pin	Description
5	SPI_SIO_CN
6	GND

**Table 3-18: BMC SPI Flash Connector Pinouts**

### 3.2.24 SPI Flash Connector (EC)

- CN Label:** JSPI2
- CN Type:** 6-pin wafer, p=1.25 mm
- CN Location:** See **Figure 3-25**
- CN Pinouts:** See **Table 3-19**

The SPI flash connector is used to flash the EC ROM.

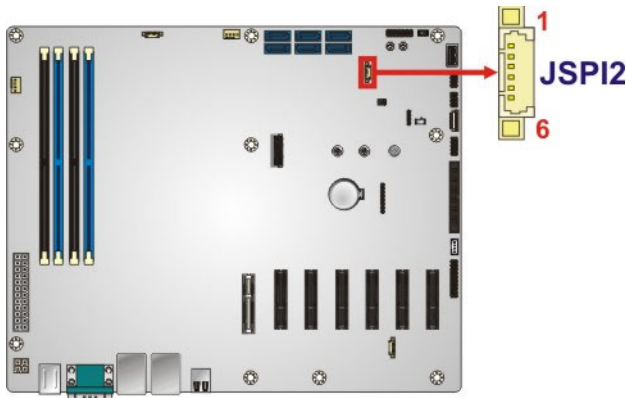

**Figure 3-25: EC SPI Flash Connector Location**

Pin	Description
1	+3.3V_EC_FLASH
2	EC_SW_FSCE#
3	EC_SW_FMISO
4	EC_SW_FSCK
5	EC_SW_FMOSI
6	GND

**Table 3-19: EC SPI Flash Connector Pinouts**

## IMBA-BDE ATX Motherboard

### 3.2.25 TPM Connector

- CN Label:** TPM1
- CN Type:** 20-pin header, p=2.54 mm
- CN Location:** See **Figure 3-26**
- CN Pinouts:** See **Table 3-20**

The TPM connector connects to a TPM module.

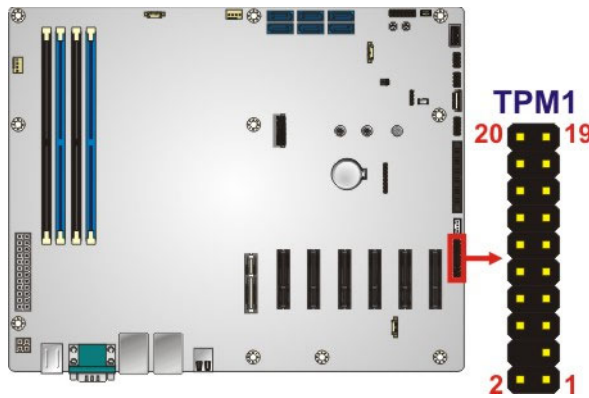

**Figure 3-26: TPM Connector Location**

Pin	Description	Pin	Description
1	LCLK	2	GND
3	LFRAME#	4	KEY
5	LRERST#	6	+5V
7	LAD3	8	LAD2
9	+3V	10	LAD1
11	LAD0	12	GND
13	SCL	14	SDA
15	SB3V	16	SERIRQ
17	GND	18	GLKRUN#
19	LPCPD#	20	LDRO#

**Table 3-20: TPM Connector Pinouts**

**3.2.26 USB 2.0 Connectors**

- CN Label:** USB1, USB2
- CN Type:** 8-pin header, p=2.54 mm
- CN Location:** See **Figure 3-27**
- CN Pinouts:** See **Table 3-21**

The USB 2.0 connectors connect to USB 2.0 devices. Each pin header provides two USB 2.0 ports.

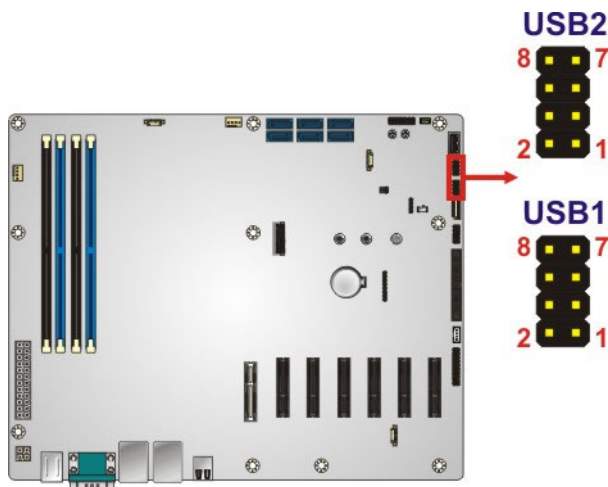

**Figure 3-27: USB 2.0 Connector Locations**

Pin	Description	Pin	Description
1	VCC	2	GND
3	DATA-	4	DATA+
5	DATA+	6	DATA-
7	GND	8	VCC

**Table 3-21: USB 2.0 Connector Pinouts**

## IMBA-BDE ATX Motherboard

### 3.2.27 USB 2.0 Connector (Type A)

- CN Label:** USB3
- CN Type:** USB 2.0, Type A
- CN Location:** See **Figure 3-28**
- CN Pinouts:** See **Table 3-22**

The USB Type A connector connects to a USB 2.0/1.1 device.

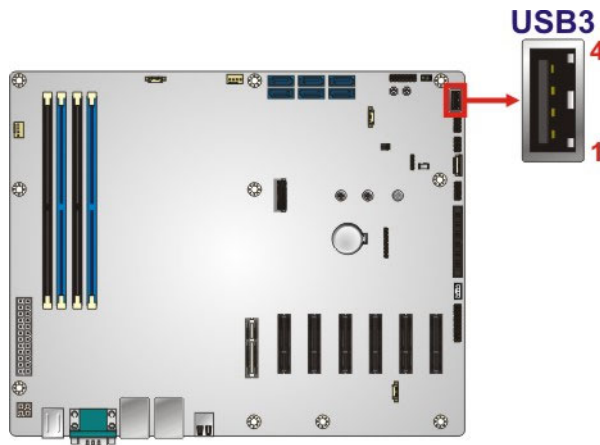

**Figure 3-28: USB 2.0 Connector (Type A) Pinout Location**

Pin	Description
1	VCC
2	DATA-
3	DATA+
4	GND

**Table 3-22: USB 2.0 Connector (Type A) Pinouts**



### 3.3 External Interface Connectors

The figure below shows the external peripheral interface connector (EPIC) panel. The EPIC panel consists of the following:

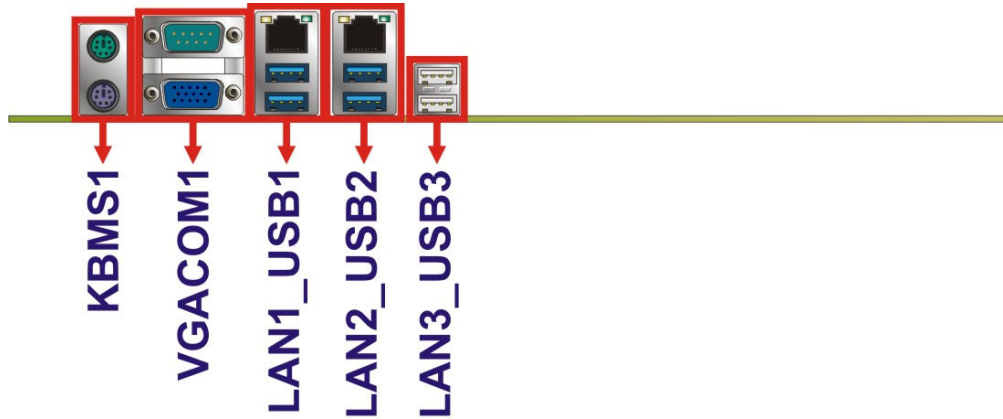

**Figure 3-29: External Interface Connectors**

#### 3.3.1 Ethernet and USB 3.0 Connectors

- CN Label:** LAN1\_USB1, LAN2\_USB2
- CN Type:** RJ-45, USB 3.0
- CN Location:** See **Figure 3-29**
- CN Pinouts:** See **Table 3-23** and **Table 3-24**

There are four external USB 3.0 connectors on the IMBA-BDE.

Pin	Description
1	VBUS
2	D1-
3	D1+
4	GND1
5	STDA_SSRX1_N
6	STDA_SSRX1_P
7	GND_DRAIN
8	STDA_STX1_N
9	STDA_STX1_P

**Table 3-23: USB 3.0 Port Pinouts**

## IMBA-BDE ATX Motherboard

Each LAN connector connects to a local network

Pin	Description	Pin	Description
1	MD0+	2	MD0-
3	MD1+	4	MD1-
5	MD2+	6	MD2-
7	MD3+	8	MD3-
9	VCC	10	GND
11	LINK_ACT+	12	LINK_ACT-
13	100-	14	1000-
15	GND		

**Table 3-24: LAN Pinouts**

### 3.3.2 PS/2 Keyboard and Mouse Connectors

**CN Label:** KBMS1

**CN Type:** Dual PS/2

**CN Location:** See **Figure 3-29**

**CN Pinouts:** See **Table 3-25** and **Figure 3-30**

The PS/2 ports are for connecting a PS/2 mouse and a PS/2 keyboard.

Pin	Description	Pin	Description
1	Keyboard Data	7	Mouse Data
2	NC	8	NC
3	GND	9	GND
4	VCC	10	VCC
5	Keyboard Clock	11	Mouse Clock
6	NC	12	NC

**Table 3-25: PS/2 Keyboard and Mouse Connector Pinouts**

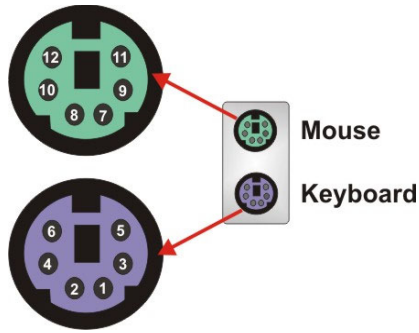

**Figure 3-30: PS/2 Keyboard and Mouse Connectors**

### 3.3.3 Serial Port and VGA Connector

- CN Label:** VGACOM1
- CN Type:** DB-9 male and DB-15 female
- CN Location:** See **Figure 3-29**
- CN Pinouts:** See **Table 3-26**, **Figure 3-31**, **Table 3-27** and **Figure 3-32**

The serial port connects to a RS-232 serial communications device.

Pin	Description	Pin	Description
1	DCD1	6	DSR1
2	RXD1	7	RTS1
3	TXD1	8	CTS1
4	DTR1	9	RI1
5	GND1		

**Table 3-26: RS-232 Serial Port Connector Pinouts**

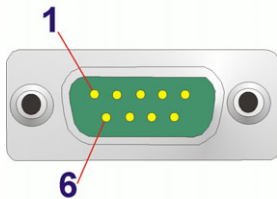

**Figure 3-31: RS-232 Serial Port Connector Pinouts**

## IMBA-BDE ATX Motherboard

The VGA connector connects to a monitor that accepts a standard VGA input.

PIN	DESCRIPTION	PIN	DESCRIPTION
1	RED	2	GREEN
3	BLUE	4	NC
5	GND	6	CRT_PLUG#
7	GND	8	GND
9	VCC	10	GND
11	NC	12	DCCDAT
13	HSYNC	14	VSYNC
15	DDCCLK		

**Table 3-27: VGA Connector Pinouts**

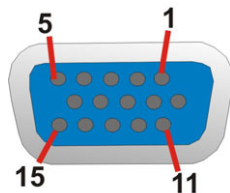

**Figure 3-32: VGA Connector**

### 3.3.4 USB 2.0 Connectors

<b>CN Label:</b>	<b>LAN3_USB3</b>
<b>CN Type:</b>	USB 2.0 port
<b>CN Location:</b>	See <b>Figure 3-29</b>
<b>CN Pinouts:</b>	See <b>Table 3-28</b>

The USB 2.0 connector can be connected to a USB 2.0/1.1 device.

Pin	Description
1	VBUS
2	DATA-
3	DATA+
4	GND

**Table 3-28: USB 2.0 Port Pinouts**

Chapter

4

# Installation

---

## IMBA-BDE ATX Motherboard

### 4.1 Anti-static Precautions

---



#### WARNING:

Failure to take ESD precautions during installation may result in permanent damage to the product and severe injury to the user.

---

Electrostatic discharge (ESD) can cause serious damage to electronic components, including the IMBA-BDE. Dry climates are especially susceptible to ESD. It is therefore critical to strictly adhere to the following anti-static precautions whenever the IMBA-BDE, or any other electrical component, is handled.

- **Wear an anti-static wristband:** - Wearing a simple anti-static wristband can help to prevent ESD from damaging the board.
- **Self-grounding:** - Before handling the board touch any grounded conducting material. During the time the board is handled, frequently touch any conducting materials that are connected to the ground.
- **Use an anti-static pad:** When configuring the IMBA-BDE, place it on an anti-static pad. This reduces the possibility of ESD damaging the IMBA-BDE.
- **Only handle the edges of the PCB:-** When handling the PCB, hold it by the edges.

### 4.2 Installation Considerations

---



#### NOTE:

The following installation notices and installation considerations should be read and understood before the IMBA-BDE is installed. All installation notices pertaining to the installation of IMBA-BDE should be strictly adhered to. Failing to adhere to these precautions may lead to severe damage of the IMBA-BDE and injury to the person installing the motherboard.

---

**WARNING:**

The installation instructions described in this manual should be carefully followed in order to prevent damage to the IMBA-BDE, IMBA-BDE components and injury to the user.

Before and during the installation please **DO** the following:

- **Read the user manual:**
  - The user manual provides a complete description of the installation instructions and configuration options.
- **Wear an electrostatic discharge cuff (ESD):**
  - Electronic components are easily damaged by ESD. Wearing an ESD cuff removes ESD from the body and helps prevent ESD damage.
- **Place on an anti-static pad:**
  - When installing or configuring the motherboard, place it on an anti-static pad. This helps to prevent potential ESD damage.
- **Turn all power off:**
  - Make sure the product is disconnected from all power supplies and that no electricity is being fed into the system.

Before and during the installation of the IMBA-BDE, **DO NOT:**

- Remove any of the stickers on the PCB board. These stickers are required for warranty validation.
- Use the product before verifying all the cables and power connectors are properly connected.
- Allow screws to come in contact with the PCB circuit, connector pins, or its components.

### 4.3 DIMM Installation

To install a DIMM, please follow the steps below and refer to **Figure 4-1**.

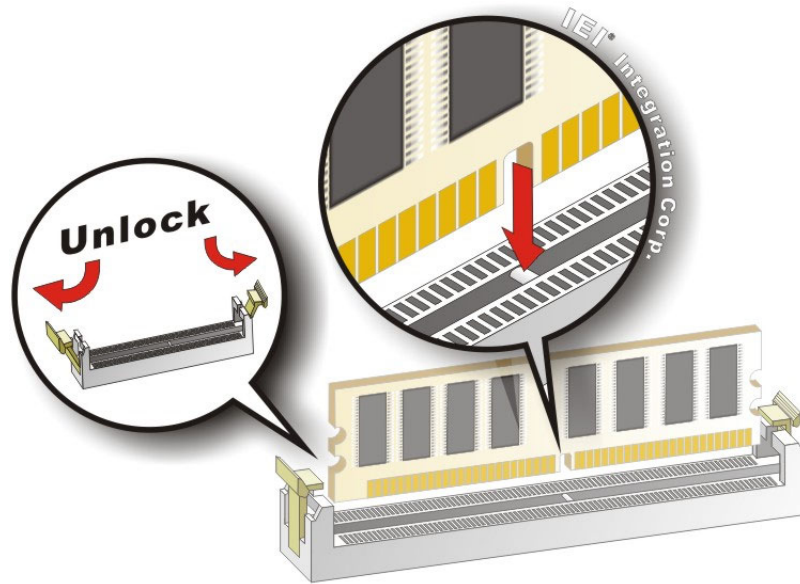

**Figure 4-1: DIMM Installation**

- Step 1: Open the DIMM socket handles.** Open the two handles outwards as far as they can. See **Figure 4-1**.
- Step 2: Align the DIMM with the socket.** Align the DIMM so the notch on the memory lines up with the notch on the memory socket. See **Figure 4-1**.
- Step 3: Insert the DIMM.** Once aligned, press down until the DIMM is properly seated. Clip the two handles into place. See **Figure 4-1**.
- Step 4: Removing a DIMM.** To remove a DIMM, push both handles outward. The memory module is ejected by a mechanism in the socket.



## 4.4 M.2 Module Installation



### NOTE:

If the SATA signal of the M.2 slot (**CON9**) is being used, such as an M.2 SSD is installed to the M.2 slot, the **SATA5** connector will be disabled.

The M.2 slot is keyed in the M position and provides the mounting screw position for 2242/2260/2280-size M.2 module. To install a 2280-size M.2 module, please follow the steps below.

**Step 1:** Locate the M.2 module slot. See **Chapter 3**.

**Step 2:** Remove the on-board retention screw as shown in **Figure 4-2**.

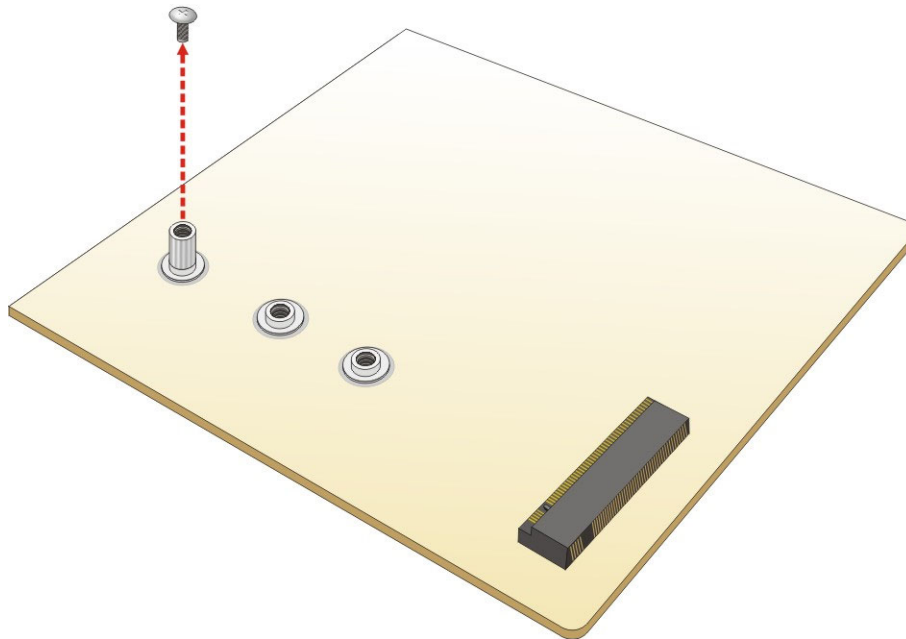

**Figure 4-2: Removing the M.2 Module Retention Screw**

## IMBA-BDE ATX Motherboard

**Step 3:** Line up the notch on the module with the notch on the slot. Slide the M.2 module into the socket at an angle of about 20° (Figure 4-3).

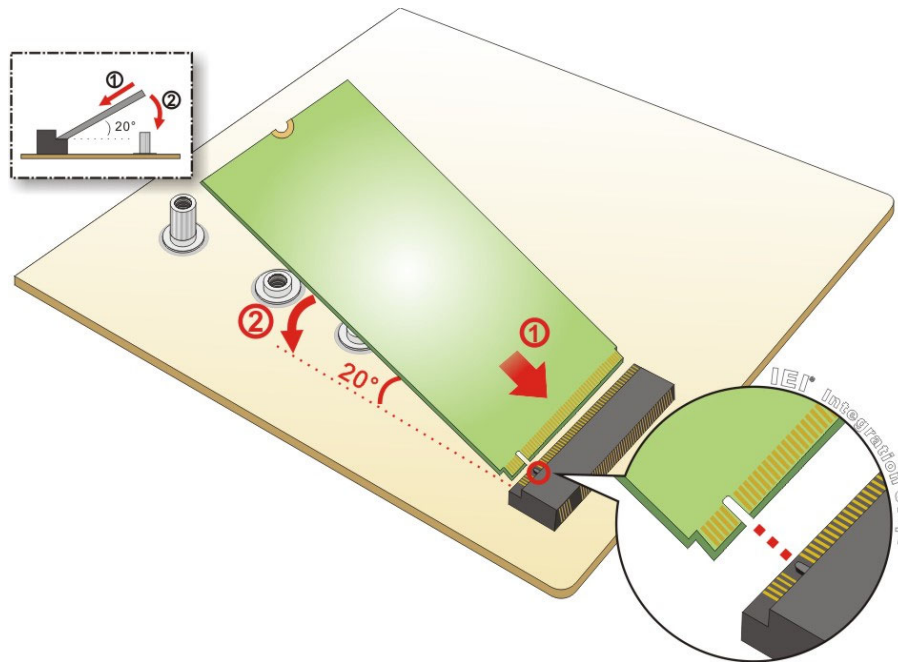

Figure 4-3: Inserting the M.2 Module into the Slot at an Angle

**Step 4:** Push the M.2 module down and secure it with the previously removed retention screw (Figure 4-4).

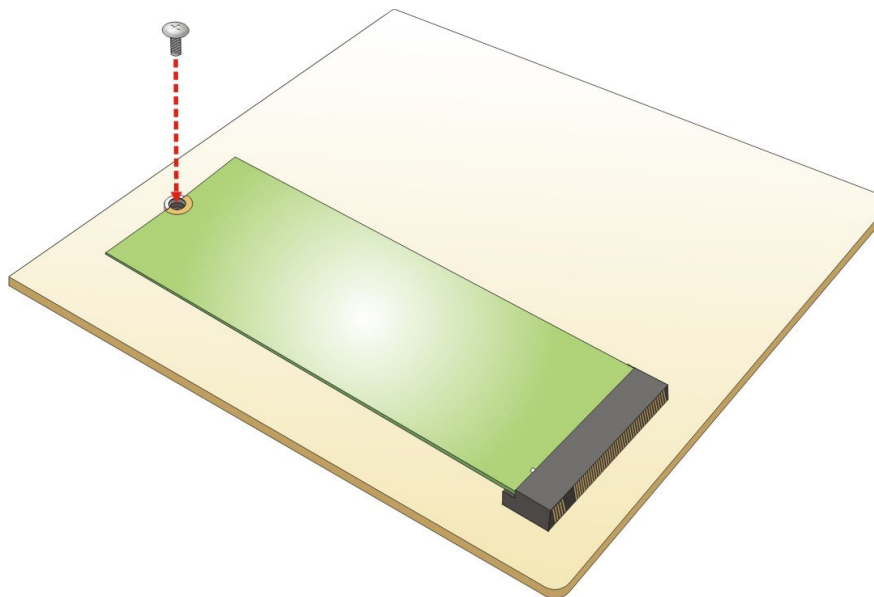
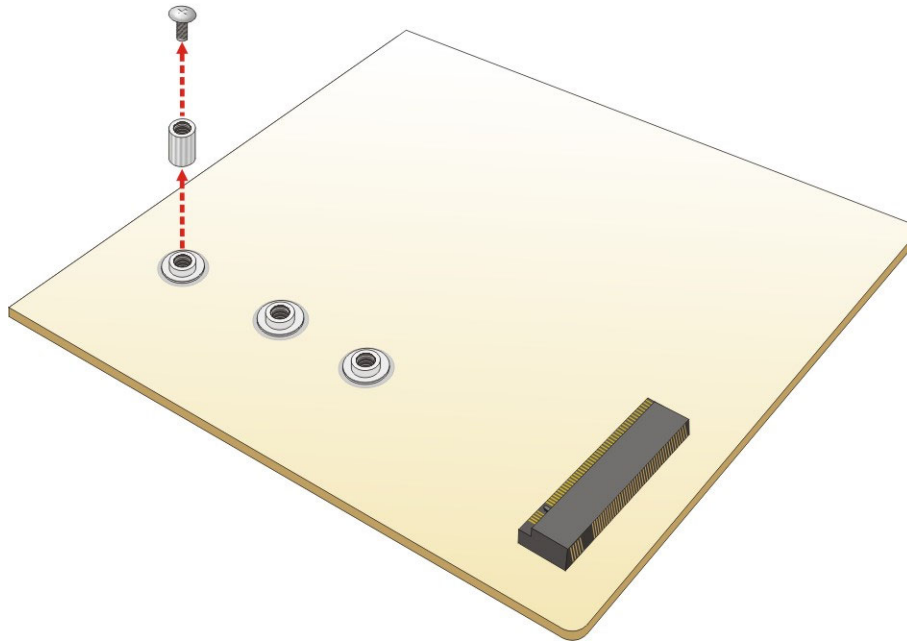

Figure 4-4: Securing the M.2 Module

To install a 2242/2260-size M.2 module, please follow the steps below.

**Step 1:** Locate the M.2 module slot. See **Chapter 3**.

**Step 2:** Remove the retention screw and standoff as shown in **Figure 4-5**.



**Figure 4-5: Removing the M.2 Module Retention Screw and Standoff**

**Step 3:** Install the previously removed standoff to the screw hole for the 2242/2260-size M.2 module (**Figure 4-6**).

**Step 4:** Follow **Step 3 ~ Step 4** on previous page to insert and secure the 2242/2260-size M.2 module.

## IMBA-BDE ATX Motherboard

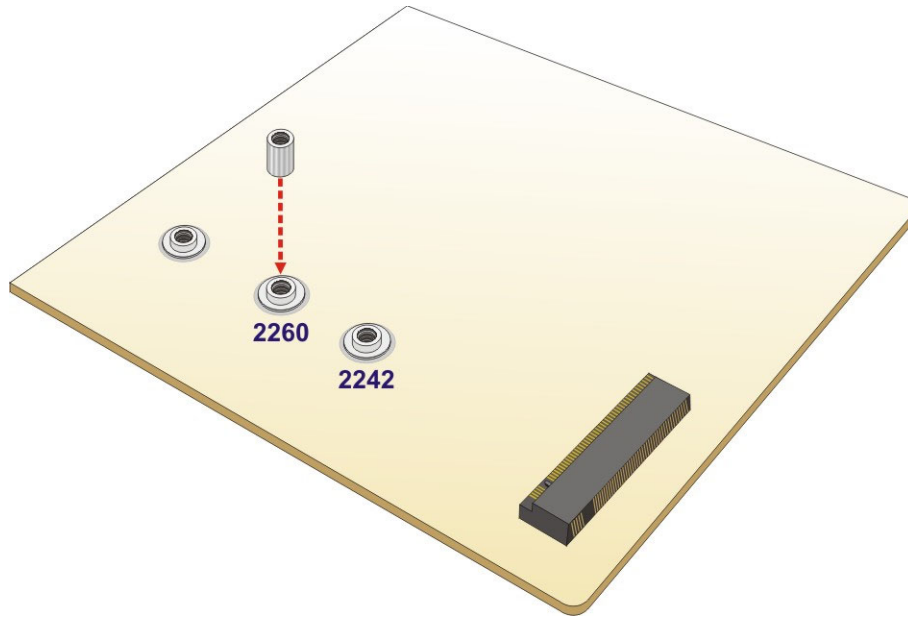

Figure 4-6: Installing the Standoff

### 4.5 System Configuration

The system configuration is controlled by buttons/jumpers/switches, and should be performed before installation.

#### 4.5.1 AT/ATX Power Mode Selection

The AT and ATX power mode selection is made through the AT/ATX power mode switch which is shown in **Figure 4-7**.

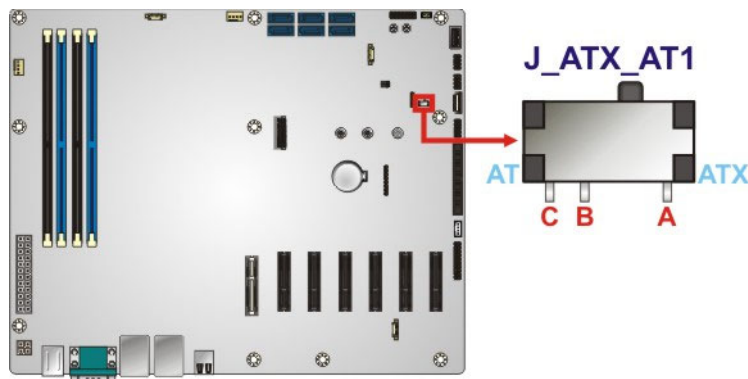

Figure 4-7: AT/ATX Power Mode Switch Location

Setting	Description
A-B	ATX power mode (default)
B-C	AT power mode

**Table 4-1: AT/ATX Power Mode Switch Settings**

### 4.5.2 Clear CMOS Jumpers

- Jumper Label:** JP2, JP3
- Jumper Type:** 3-pin header, p=2 mm
- Jumper Settings:** See Table 4-2
- Jumper Location:** See Figure 4-8

To reset the BIOS, move the jumper of the **JP2** header to the "Clear CMOS" position for 3 seconds or more, and then move back to the default position. In addition, the **JP3** header is the secondary clear CMOS jumper that can reset the ME.

Setting	Description
Short 1-2	Normal (default)
Short 2-3	Clear CMOS

**Table 4-2: Clear CMOS Jumper Settings**

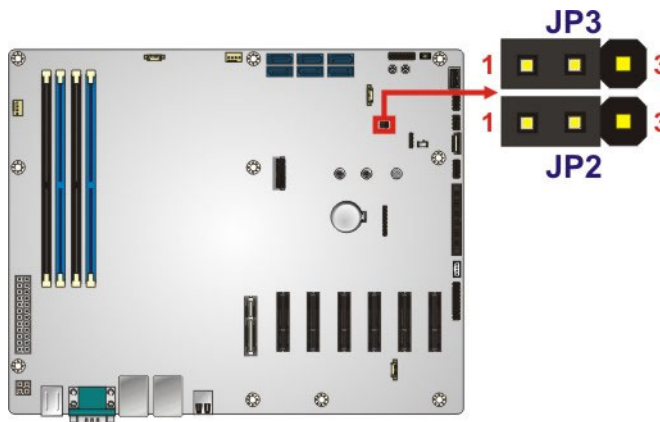

**Figure 4-8: Clear CMOS Jumper Locations**

## 4.6 Internal Peripheral Device Connections

This section outlines the installation of peripheral devices to the onboard connectors.

### 4.6.1 SATA Drive Connection

The IMBA-BDE is shipped with two SATA drive cables. To connect the SATA drive to the connector, please follow the steps below.

**Step 1: Locate the connectors.** The locations of the SATA drive connectors are shown in **Chapter 3**.

**Step 2: Insert the cable connector.** Insert the cable connector into the on-board SATA drive connector until it clips into place. See **Figure 4-9**.

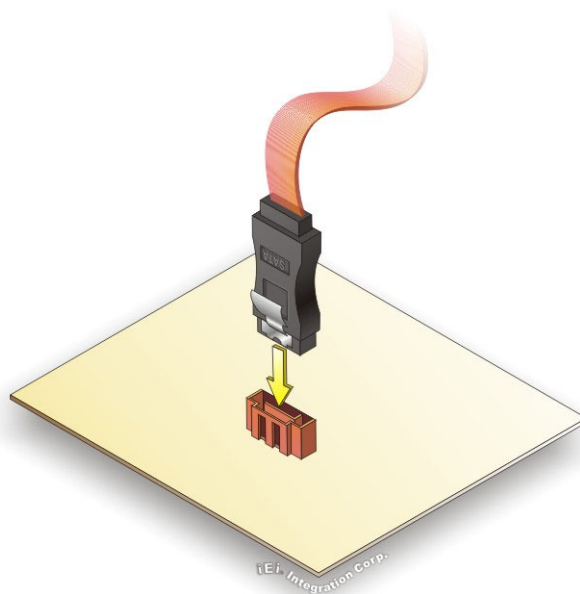

**Figure 4-9: SATA Drive Cable Connection**

**Step 3: Connect the cable to the SATA disk.** Connect the connector on the other end of the cable to the connector at the back of the SATA drive. See **Figure 4-10**.

**Step 4: Connect the SATA power cable.** Connect the SATA power connector to the back of the SATA drive. See **Figure 4-10**.

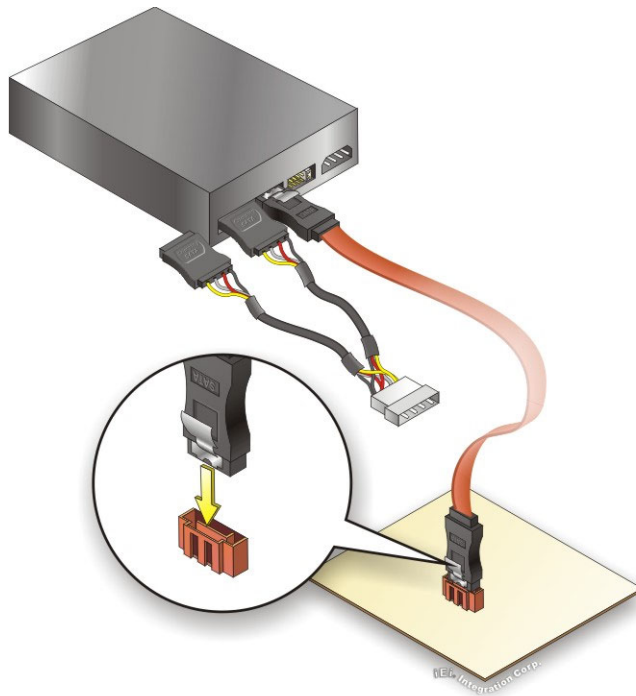

**Figure 4-10: SATA Power Drive Connection**

The SATA power cable can be bought from IEI. See **Optional Items** in Section 2.4.

## 4.7 Driver Installation

All the drivers for the IMBA-BDE are on the CD that came with the system. To install the drivers, please follow the steps below.



### **NOTE:**

The content of the CD may vary throughout the life cycle of the product and is subject to change without prior notice. Visit the IEI website or contact technical support for the latest updates.

**Step 1:** Insert the CD into a CD drive connected to the system.

## IMBA-BDE ATX Motherboard

---



### NOTE:

If the installation program doesn't start automatically:  
Click "Start->My Computer->CD Drive->autorun.exe"

---

**Step 2:** The driver main menu appears. Click IMBA-BDE.

**Step 3:** A new screen with a list of available drivers appears.

**Step 4:** Install all of the necessary drivers in the menu.



Chapter

**5**

**BIOS**

---

## IMBA-BDE ATX Motherboard

### 5.1 Introduction

The BIOS is programmed onto the BIOS chip. The BIOS setup program allows changes to certain system settings. This chapter outlines the options that can be changed.



#### NOTE:

Some of the BIOS options may vary throughout the life cycle of the product and are subject to change without prior notice.

#### 5.1.1 Starting Setup

The UEFI BIOS is activated when the computer is turned on. The setup program can be activated by pressing the **DEL** or **F2** key as soon as the system is turned on.

If the system enters the OS environment before the **DEL** or **F2** key is pressed, restart the computer and try again.

#### 5.1.2 Using Setup

Use the arrow keys to highlight items, press **ENTER** to select, use the PageUp and PageDown keys to change entries, press **F1** for help and press **ESC** to quit. Navigation keys are shown in the following table.

Key	Function
Up arrow	Move to previous item
Down arrow	Move to next item
Left arrow	Move to the item on the left hand side
Right arrow	Move to the item on the right hand side
+	Increase the numeric value or make changes
-	Decrease the numeric value or make changes
Esc key	Main Menu – Quit and not save changes into CMOS Status Page Setup Menu and Option Page Setup Menu -- Exit current page and return to Main Menu

Key	Function
F1	General help, only for Status Page Setup Menu and Option Page Setup Menu
F2	Load previous values
F3	Load optimized defaults
F4	Save changes and Exit BIOS

Table 5-1: BIOS Navigation Keys

### 5.1.3 Getting Help

When **F1** is pressed a small help window describing the appropriate keys to use and the possible selections for the highlighted item appears. To exit the Help Window press **Esc** or the **F1** key again.

### 5.1.4 Unable to Reboot after Configuration Changes

If the computer cannot boot after changes to the system configuration are made, CMOS defaults. Use the clear CMOS button described in **Section 4.5.2**.

### 5.1.5 BIOS Menu Bar

The **menu bar** on top of the BIOS screen has the following main items:

- Main – Changes the basic system configuration.
- Advanced – Changes the advanced system settings.
- IntelRCSetup– Changes the processor and PCH settings.
- Security – Sets User and Supervisor Passwords.
- Boot – Changes the system boot configuration.
- Save & Exit – Selects exit options and loads default settings.

The following sections completely describe the configuration options found in the menu items at the top of the BIOS screen and listed above.

## IMBA-BDE ATX Motherboard

### 5.2 Main

The **Main** BIOS menu (**BIOS Menu 1**) appears when the **BIOS Setup** program is entered. The **Main** menu gives an overview of the basic system information.

Aptio Setup Utility - Copyright (C) 2017 American Megatrends, Inc.		
Main	Advanced	IntelRCSetup Security Boot Save & Exit
BIOS Information		Set the Date. Use Tab to switch between Date elements.
BIOS Vendor	American Megatrends	
Core Version	5.11	
Compliance	UEFI 2.4; PI 1.3	
Project Version	SAD7AR12.ROM	
Build Date and Time	06/13/2017 20:09:10	----- →←: Select Screen ↑↓: Select Item Enter: Select +/-: Change Opt. F1: General Help F2: Previous Values F3: Optimized Defaults F4: Save & Exit ESC: Exit
iWDD Vendor	iEi	
iWDD Version	SAD7ER10.bin	
Access Level	Administrator	
Memory Information		
Total Memory	4096 MB	
System Date	[Tue 06/20/2017]	
System Time	[15:10:27]	
Version 2.18.1260. Copyright (C) 2017 American Megatrends, Inc.		

#### BIOS Menu 1: Main

The Main menu has two user configurable fields:

➔ **System Date [xx/xx/xx]**

Use the **System Date** option to set the system date. Manually enter the day, month and year.

➔ **System Time [xx:xx:xx]**

Use the **System Time** option to set the system time. Manually enter the hours, minutes and seconds.

## 5.3 Advanced

Use the **Advanced** menu (**BIOS Menu 2**) to configure the peripheral devices through the following sub-menus:



### WARNING:

Setting the wrong values in the sections below may cause the system to malfunction. Make sure that the settings made are compatible with the hardware.

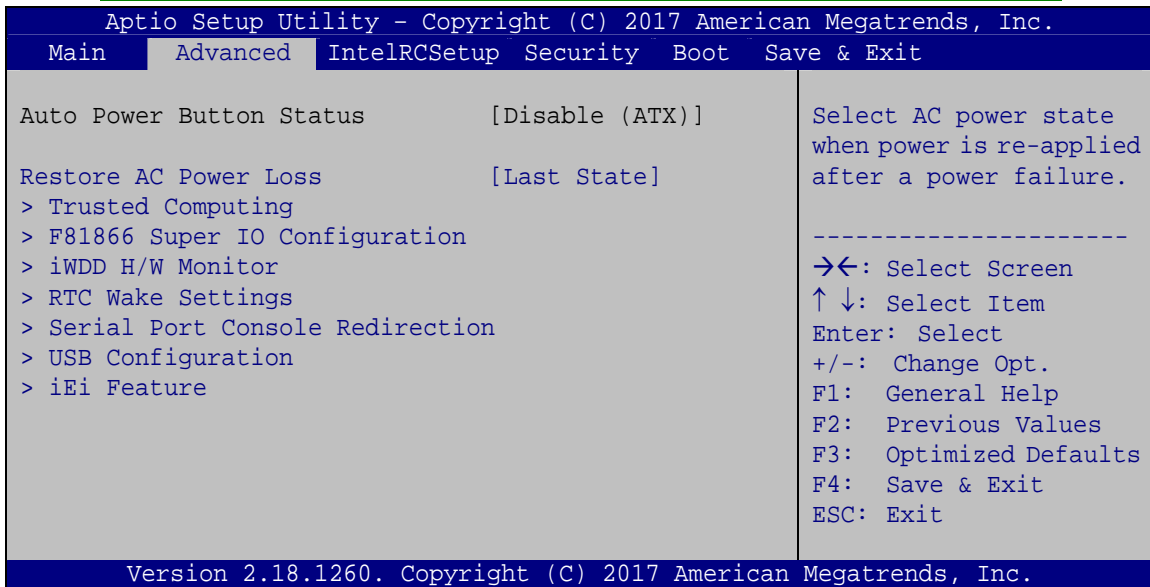

### BIOS Menu 2: Advanced

#### ➔ Restore AC Power Loss [Last State]

Use the **Restore AC Power Loss** BIOS option to specify what state the system returns to if there is a sudden loss of power to the system.

- ➔ **Power Off**                      The system remains turned off
- ➔ **Power On**                        The system turns on
- ➔ **Last State**    **DEFAULT**      The system returns to its previous state. If it was on, it turns itself on. If it was off, it remains off.

## IMBA-BDE ATX Motherboard

### 5.3.1 Trusted Computing

Use the **Trusted Computing** menu (**BIOS Menu 3**) to configure settings related to the Trusted Computing Group (TCG) Trusted Platform Module (TPM).

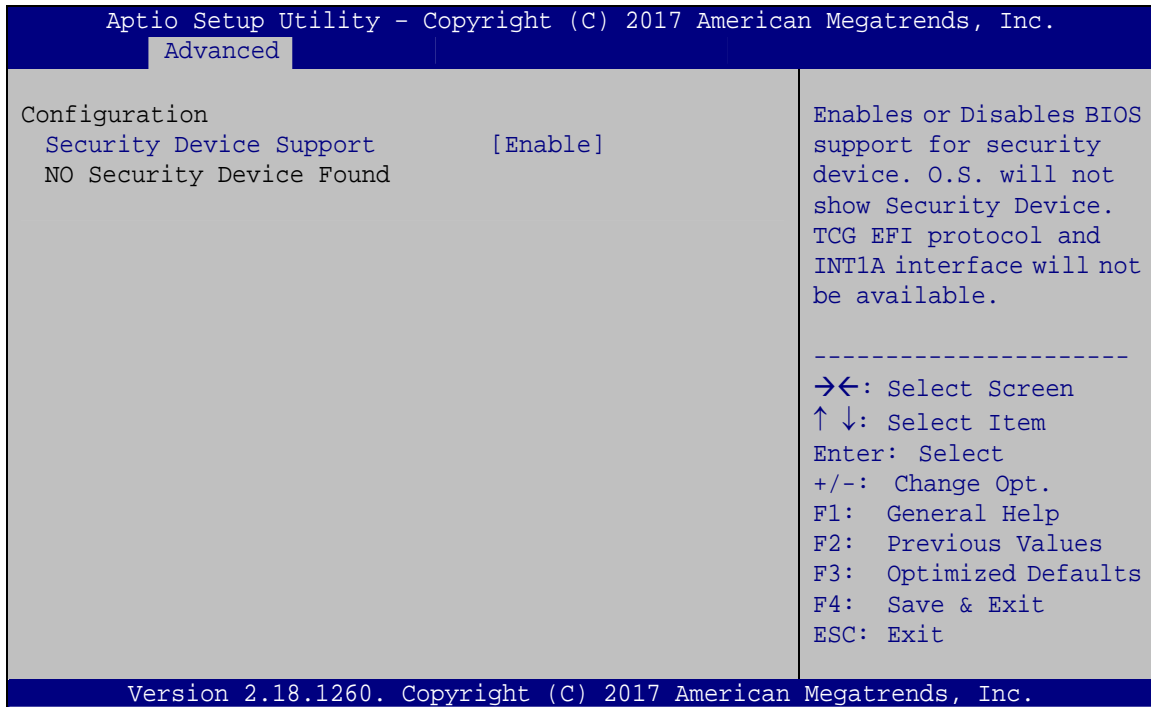

#### BIOS Menu 3: Trusted Computing

##### ➔ Security Device Support [Enable]

Use the **Security Device Support** option to configure support for the TPM.

- ➔ **Disable**    DEFAULT    TPM support is disabled.
- ➔ **Enable**                    TPM support is enabled.

### 5.3.2 F81866 Super IO Configuration

Use the **F81866 Super IO Configuration** menu (**BIOS Menu 4**) to set or change the configurations for the serial ports.

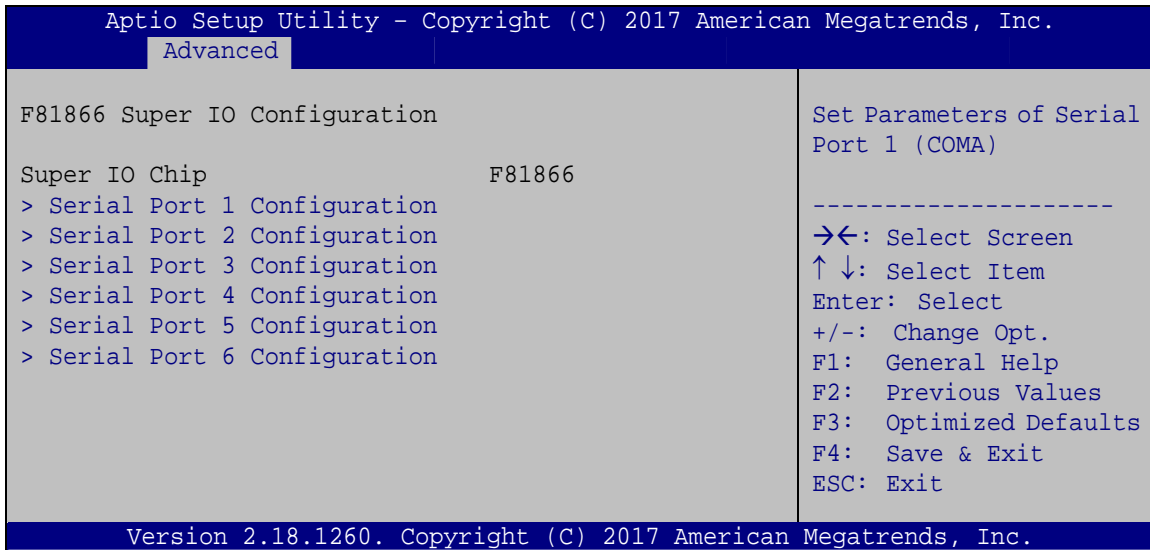

**BIOS Menu 4: F81866 Super IO Configuration**

#### 5.3.2.1 Serial Port n Configuration

Use the **Serial Port n Configuration** menu (**BIOS Menu 5**) to configure the serial port n.

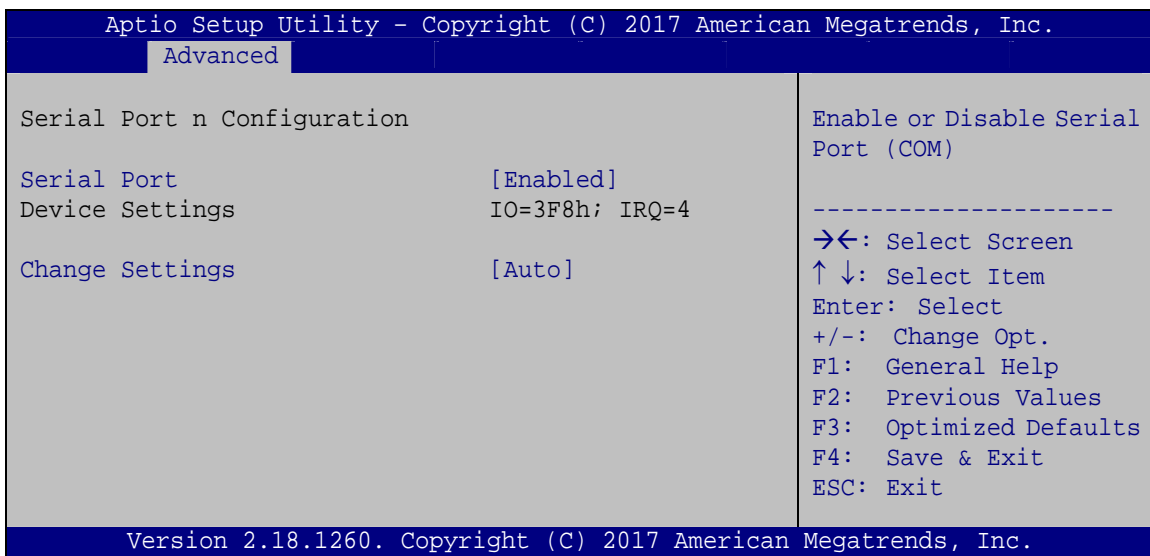

**BIOS Menu 5: Serial Port n Configuration Menu**

## IMBA-BDE ATX Motherboard

## 5.3.2.1.1 Serial Port 1 Configuration

## ➔ Serial Port [Enabled]

Use the **Serial Port** option to enable or disable the serial port.

- ➔ **Disabled**                      Disable the serial port
- ➔ **Enabled**      **DEFAULT**      Enable the serial port

## ➔ Change Settings [Auto]

Use the **Change Settings** option to change the serial port IO port address and interrupt address.

- ➔ **Auto**                              The serial port IO port address and interrupt address are automatically detected.
- ➔ **IO=3F8h;  
IRQ=4**                              Serial Port I/O port address is 3F8h and the interrupt address is IRQ4
- ➔ **IO=3F8h;  
IRQ=3, 4,  
5, 6, 7, 9,  
10, 11, 12**                              Serial Port I/O port address is 3F8h and the interrupt address is IRQ3, 4, 5, 6, 7, 9, 10, 11, 12
- ➔ **IO=2F8h;  
IRQ=3, 4,  
5, 6, 7, 9,  
10, 11, 12**                              Serial Port I/O port address is 2F8h and the interrupt address is IRQ3, 4, 5, 6, 7, 9, 10, 11, 12
- ➔ **IO=3E8h;  
IRQ=3, 4,  
5, 6, 7, 9,  
10, 11, 12**                              Serial Port I/O port address is 3E8h and the interrupt address is IRQ3, 4, 5, 6, 7, 9, 10, 11, 12
- ➔ **IO=2E8h;  
IRQ=3, 4,  
5, 6, 7, 9,  
10, 11, 12**                              Serial Port I/O port address is 2E8h and the interrupt address is IRQ3, 4, 5, 6, 7, 9, 10, 11, 12



**5.3.2.1.2 Serial Port 2 Configuration**

➔ **Serial Port [Enabled]**

Use the **Serial Port** option to enable or disable the serial port.

- ➔ **Disabled**                      Disable the serial port
- ➔ **Enabled      DEFAULT**      Enable the serial port

➔ **Change Settings [Auto]**

Use the **Change Settings** option to change the serial port IO port address and interrupt address.

- ➔ **Auto**                              The serial port IO port address and interrupt address are automatically detected.
- ➔ **IO=2F8h;  
IRQ=3**                              Serial Port I/O port address is 2F8h and the interrupt address is IRQ3
- ➔ **IO=3F8h;  
IRQ=3, 4,  
5, 6, 7, 9,  
10, 11, 12**                              Serial Port I/O port address is 3F8h and the interrupt address is IRQ3, 4, 5, 6, 7, 9, 10, 11, 12
- ➔ **IO=2F8h;  
IRQ=3, 4,  
5, 6, 7, 9,  
10, 11, 12**                              Serial Port I/O port address is 2F8h and the interrupt address is IRQ3, 4, 5, 6, 7, 9, 10, 11, 12
- ➔ **IO=3E8h;  
IRQ=3, 4,  
5, 6, 7, 9,  
10, 11, 12**                              Serial Port I/O port address is 3E8h and the interrupt address is IRQ3, 4, 5, 6, 7, 9, 10, 11, 12
- ➔ **IO=2E8h;  
IRQ=3, 4,  
5, 6, 7, 9,  
10, 11, 12**                              Serial Port I/O port address is 2E8h and the interrupt address is IRQ3, 4, 5, 6, 7, 9, 10, 11, 12

## IMBA-BDE ATX Motherboard

### 5.3.2.1.3 Serial Port 3 Configuration

#### → Serial Port [Enabled]

Use the **Serial Port** option to enable or disable the serial port.

- **Disabled**                      Disable the serial port
- **Enabled**      **DEFAULT**      Enable the serial port

#### → Change Settings [Auto]

Use the **Change Settings** option to change the serial port IO port address and interrupt address.

- **Auto**                              The serial port IO port address and interrupt address are automatically detected.
- **IO=3E8h;  
IRQ=11**                              Serial Port I/O port address is 3E8h and the interrupt address is IRQ11
- **IO=3E8h;  
IRQ=3, 4,  
5, 6, 7, 9,  
10, 11, 12**                              Serial Port I/O port address is 3E8h and the interrupt address is IRQ3, 4, 5, 6, 7, 9, 10, 11, 12
- **IO=2E8h;  
IRQ=3, 4,  
5, 6, 7, 9,  
10, 11, 12**                              Serial Port I/O port address is 2E8h and the interrupt address is IRQ3, 4, 5, 6, 7, 9, 10, 11, 12
- **IO=2D0h;  
IRQ=3, 4,  
5, 6, 7, 9,  
10, 11, 12**                              Serial Port I/O port address is 2D0h and the interrupt address is IRQ3, 4, 5, 6, 7, 9, 10, 11, 12
- **IO=2E0h;  
IRQ=3, 4,  
5, 6, 7, 9,  
10, 11, 12**                              Serial Port I/O port address is 2E0h and the interrupt address is IRQ3, 4, 5, 6, 7, 9, 10, 11, 12

### 5.3.2.1.4 Serial Port 4 Configuration

➔ **Serial Port [Enabled]**

Use the **Serial Port** option to enable or disable the serial port.

- ➔ **Disabled**                      Disable the serial port
- ➔ **Enabled      DEFAULT**      Enable the serial port

➔ **Change Settings [Auto]**

Use the **Change Settings** option to change the serial port IO port address and interrupt address.

- ➔ **Auto**                              The serial port IO port address and interrupt address are automatically detected.
- ➔ **IO=2E8h;  
IRQ=11**                              Serial Port I/O port address is 2E8h and the interrupt address is IRQ11
- ➔ **IO=3E8h;  
IRQ=3, 4,  
5, 6, 7, 9,  
10, 11, 12**                              Serial Port I/O port address is 3E8h and the interrupt address is IRQ3, 4, 5, 6, 7, 9, 10, 11, 12
- ➔ **IO=2E8h;  
IRQ=3, 4,  
5, 6, 7, 9,  
10, 11, 12**                              Serial Port I/O port address is 2E8h and the interrupt address is IRQ3, 4, 5, 6, 7, 9, 10, 11, 12
- ➔ **IO=2D0h;  
IRQ=3, 4,  
5, 6, 7, 9,  
10, 11, 12**                              Serial Port I/O port address is 2D0h and the interrupt address is IRQ3, 4, 5, 6, 7, 9, 10, 11, 12
- ➔ **IO=2E0h;  
IRQ=3, 4,  
5, 6, 7, 9,  
10, 11, 12**                              Serial Port I/O port address is 2E0h and the interrupt address is IRQ3, 4, 5, 6, 7, 9, 10, 11, 12

## IMBA-BDE ATX Motherboard

### 5.3.2.1.5 Serial Port 5 Configuration

#### → Serial Port [Enabled]

Use the **Serial Port** option to enable or disable the serial port.

- **Disabled**                      Disable the serial port
- **Enabled**      **DEFAULT**      Enable the serial port

#### → Change Settings [Auto]

Use the **Change Settings** option to change the serial port IO port address and interrupt address.

- **Auto**                              The serial port IO port address and interrupt address are automatically detected.
- **IO=2D0h;  
IRQ=11**                              Serial Port I/O port address is 2D0h and the interrupt address is IRQ11
- **IO=3E8h;  
IRQ=3, 4,  
5, 6, 7, 9,  
10, 11, 12**                              Serial Port I/O port address is 3E8h and the interrupt address is IRQ3, 4, 5, 6, 7, 9, 10, 11, 12
- **IO=2E8h;  
IRQ=3, 4,  
5, 6, 7, 9,  
10, 11, 12**                              Serial Port I/O port address is 2E8h and the interrupt address is IRQ3, 4, 5, 6, 7, 9, 10, 11, 12
- **IO=2D0h;  
IRQ=3, 4,  
5, 6, 7, 9,  
10, 11, 12**                              Serial Port I/O port address is 2D0h and the interrupt address is IRQ3, 4, 5, 6, 7, 9, 10, 11, 12
- **IO=2E0h;  
IRQ=3, 4,  
5, 6, 7, 9,  
10, 11, 12**                              Serial Port I/O port address is 2E0h and the interrupt address is IRQ3, 4, 5, 6, 7, 9, 10, 11, 12

### 5.3.2.1.6 Serial Port 6 Configuration

➔ **Serial Port [Enabled]**

Use the **Serial Port** option to enable or disable the serial port.

- ➔ **Disabled**                      Disable the serial port
- ➔ **Enabled      DEFAULT**      Enable the serial port

➔ **Change Settings [Auto]**

Use the **Change Settings** option to change the serial port IO port address and interrupt address.

- ➔ **Auto**                              The serial port IO port address and interrupt address are automatically detected.
- ➔ **IO=2E0h;  
IRQ=11**                              Serial Port I/O port address is 2E0h and the interrupt address is IRQ11
- ➔ **IO=3E8h;  
IRQ=3, 4,  
5, 6, 7, 9,  
10, 11, 12**                              Serial Port I/O port address is 3E8h and the interrupt address is IRQ3, 4, 5, 6, 7, 9, 10, 11, 12
- ➔ **IO=2E8h;  
IRQ=3, 4,  
5, 6, 7, 9,  
10, 11, 12**                              Serial Port I/O port address is 2E8h and the interrupt address is IRQ3, 4, 5, 6, 7, 9, 10, 11, 12
- ➔ **IO=2D0h;  
IRQ=3, 4,  
5, 6, 7, 9,  
10, 11, 12**                              Serial Port I/O port address is 2D0h and the interrupt address is IRQ3, 4, 5, 6, 7, 9, 10, 11, 12
- ➔ **IO=2E0h;  
IRQ=3, 4,  
5, 6, 7, 9,  
10, 11, 12**                              Serial Port I/O port address is 2E0h and the interrupt address is IRQ3, 4, 5, 6, 7, 9, 10, 11, 12

## IMBA-BDE ATX Motherboard

### 5.3.3 iWDD H/W Monitor

The **iWDD H/W Monitor** menu (**BIOS Menu 6**) displays the system temperatures and voltages.

```

Aptio Setup Utility - Copyright (C) 2017 American Megatrends, Inc.
-----
Advanced
-----
PC Health Status
CPU temperature           : +53 °C
System temperature       : +32 °C

FAN(CN4) Speed           : N/A
FAN(CN5) Speed           : 1399 RPM

CPU_CORE                  : +1.816 V
+5V                       : +5.161 V
+12V                      : +12.032 V
+DDR                      : +1.216 V
+5VSB                     : +5.114 V
+3.3V                     : +3.381 V
+3.3VSB                   : +3.236 V

> Smart Fan Mode Configuration

Smart Fan Mode Select
-----
-><: Select Screen
↑↓: Select Item
Enter: Select
+/-: Change Opt.
F1: General Help
F2: Previous Values
F3: Optimized Defaults
F4: Save & Exit
ESC: Exit

Version 2.18.1260. Copyright (C) 2017 American Megatrends, Inc.
  
```

#### BIOS Menu 6: iWDD H/W Monitor

##### ➔ PC Health Status

The following system parameters and values are shown. The system parameters that are monitored are:

- System Temperatures:
  - CPU Temperature
  - System Temperature
- Fan Speeds:
  - FAN(CN4) Speed
  - FAN(CN5) Speed
- System temperature
- CPU fan speed
- Voltages:
  - CPU\_CORE

- +5V
- +12V
- +DDR
- +5VSB
- +3.3V
- +3.3VSB

### 5.3.3.1 Smart Fan Mode Configuration

Use the **Smart Fan Mode Configuration** submenu (**BIOS Menu 7**) to configure smart fan temperature and speed settings.

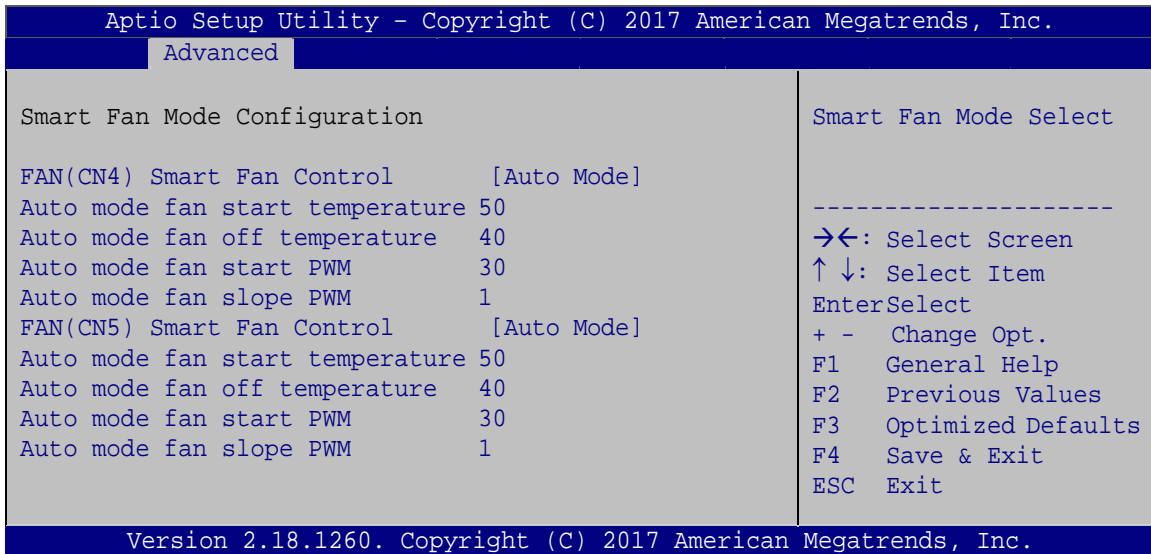

#### BIOS Menu 7: Smart Fan Mode Configuration

#### → FAN(CN4) Smart Fan Control/FAN(CN5) Smart Fan Control [Auto Mode]

Use the **FAN(CN4) Smart Fan Control/FAN(CN5) Smart Fan Control** option to configure the CPU/System Smart Fan.

- **Auto Mode**      **DEFAULT**      The fan adjusts its speed using Auto Mode settings.
- **Manual Mode**                      The fan spins at the speed set in Manual Mode settings.

## IMBA-BDE ATX Motherboard

### ➔ Auto mode fan start/off temperature

Use the + or – key to change the **Auto mode fan start/off temperature** value. Enter a decimal number between 1 and 100.

### ➔ Auto mode fan start PWM

Use the + or – key to change the **Auto mode fan start PWM** value. Enter a decimal number between 1 and 100.

### ➔ Auto mode fan slope PWM

Use the + or – key to change the **Auto mode fan slope PWM** value. Enter a decimal number between 1 and 8.

## 5.3.4 RTC Wake Settings

The **RTC Wake Settings** menu (**BIOS Menu 8**) enables the system to wake at the specified time.

```

Aptio Setup Utility - Copyright (C) 2017 American Megatrends, Inc.
  Advanced
Wake system with Fixed Time      [Disabled]
Enable or disable System
wake on alarm event. When
enabled, System will
wake on the
date::hr::min::sec
specified
-----
->←: Select Screen
↑↓: Select Item
Enter: Select
+/-: Change Opt.
F1:  General Help
F2:  Previous Values
F3:  Optimized Defaults
F4:  Save & Exit
ESC: Exit

Version 2.18.1260. Copyright (C) 2017 American Megatrends, Inc.
  
```

**BIOS Menu 8: RTC Wake Settings**



### → Wake system with Fixed Time [Disabled]

Use the **Wake system with Fixed Time** option to enable or disable the system wake on alarm event.

→ **Disabled**      **DEFAULT**      The real time clock (RTC) cannot generate a wake event

→ **Enabled**      If selected, the **Wake up every day** option appears allowing you to enable to disable the system to wake every day at the specified time. Besides, the following options appear with values that can be selected:

Wake up every day

Wake up date

Wake up hour

Wake up minute

Wake up second

After setting the alarm, the computer turns itself on from a suspend state when the alarm goes off.

### 5.3.5 Serial Port Console Redirection

The **Serial Port Console Redirection** menu (**BIOS Menu 9**) allows the console redirection options to be configured. Console redirection allows users to maintain a system remotely by re-directing keyboard input and text output through the serial port.

## IMBA-BDE ATX Motherboard

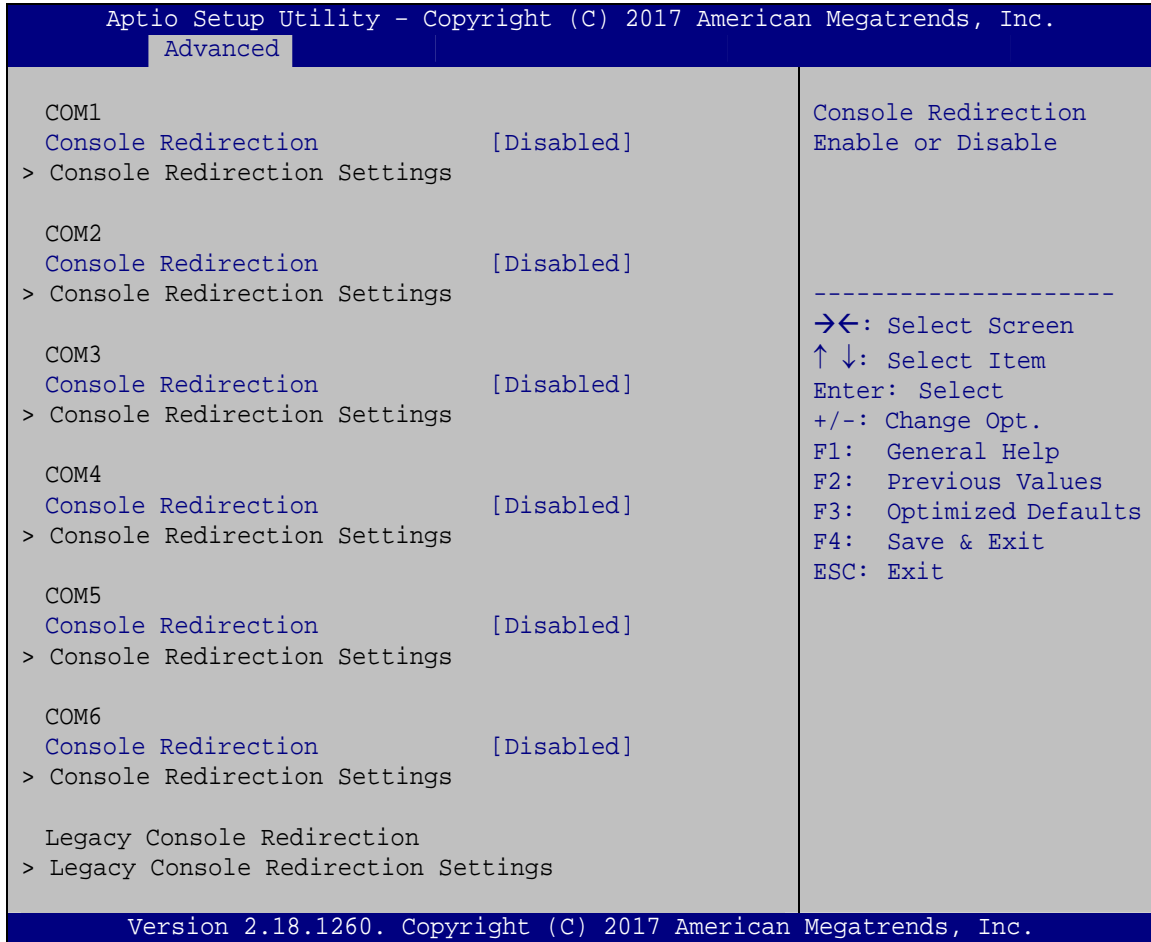

### BIOS Menu 9: Serial Port Console Redirection

#### → Console Redirection [Disabled]

Use **Console Redirection** option to enable or disable the console redirection function.

- **Disabled**      **DEFAULT**      Disabled the console redirection function
- **Enabled**                      Enabled the console redirection function



#### NOTE:

The following options are available in the **Console Redirection Settings** submenu when the **Console Redirection** option is enabled.

**→ Terminal Type [ANSI]**

Use the **Terminal Type** option to specify the remote terminal type.

- **VT100**                                      The target terminal type is VT100
- **VT100+**                                    The target terminal type is VT100+
- **VT-UTF8**                                    The target terminal type is VT-UTF8
- **ANSI**                                      **DEFAULT**                                    The target terminal type is ANSI

**→ Bits per second [115200]**

Use the **Bits per second** option to specify the serial port transmission speed. The speed must match the other side. Long or noisy lines may require lower speeds.

- **9600**                                        Sets the serial port transmission speed at 9600.
- **19200**                                       Sets the serial port transmission speed at 19200.
- **38400**                                       Sets the serial port transmission speed at 38400.
- **57600**                                       Sets the serial port transmission speed at 57600.
- **115200**                                      **DEFAULT**                                    Sets the serial port transmission speed at 115200.

**→ Data Bits [8]**

Use the **Data Bits** option to specify the number of data bits.

- **7**    Sets the data bits at 7.
- **8**    **DEFAULT**                                    Sets the data bits at 8.

**→ Parity [None]**

Use the **Parity** option to specify the parity bit that can be sent with the data bits for detecting the transmission errors.

- **None**                                      **DEFAULT**                                    No parity bit is sent with the data bits.
- **Even**                                        The parity bit is 0 if the number of ones in the data bits is even.

## IMBA-BDE ATX Motherboard

- ➔ **Odd**                                      The parity bit is 0 if the number of ones in the data bits is odd.
  - ➔ **Mark**                                      The parity bit is always 1. This option does not provide error detection.
  - ➔ **Space**                                      The parity bit is always 0. This option does not provide error detection.
- ➔ **Stop Bits [1]**
- Use the **Stop Bits** option to specify the number of stop bits used to indicate the end of a serial data packet. Communication with slow devices may require more than 1 stop bit.
- ➔ **1**                      **DEFAULT**                      Sets the number of stop bits at 1.
  - ➔ **2**    Sets the number of stop bits at 2.

### 5.3.5.1 Legacy Console Redirection Settings

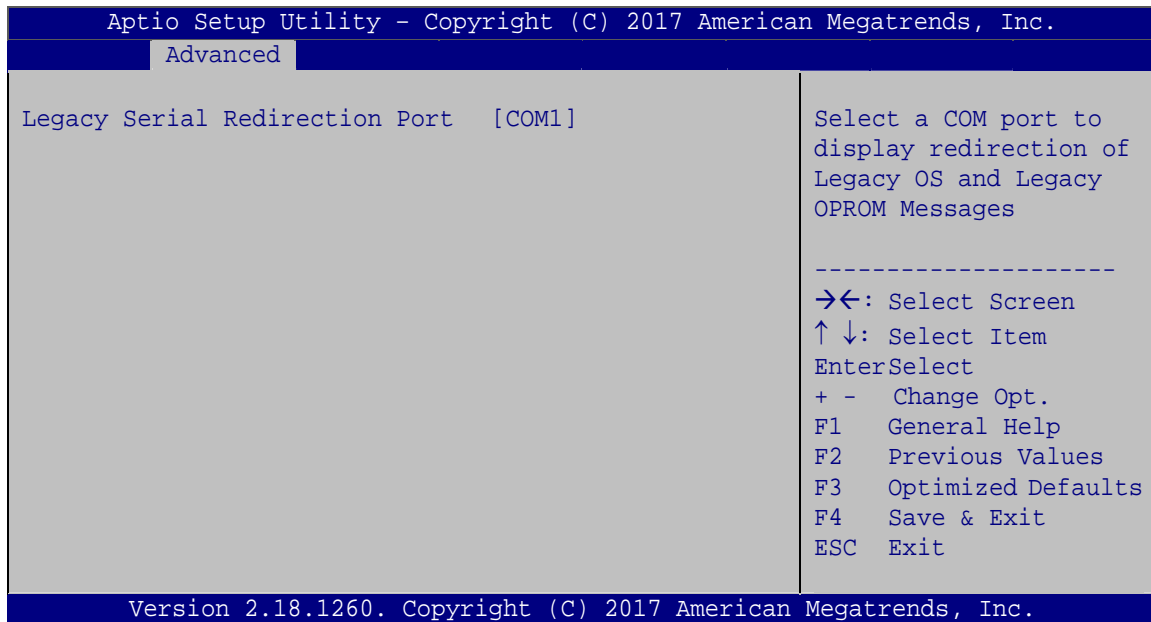

**BIOS Menu 10: Legacy Console Redirection Settings**

➔ **Legacy Serial Redirection Port [COM1]**

Use the **Legacy Serial Redirection Port** option to select a COM port to display redirection of legacy OS and legacy OPROM messages. Configuration options are listed below.

- COM1 **Default**
- COM2
- COM3
- COM4
- COM5
- COM6

**5.3.6 USB Configuration**

Use the **USB Configuration** menu (**BIOS Menu 11**) to read USB configuration information and configure the USB settings.

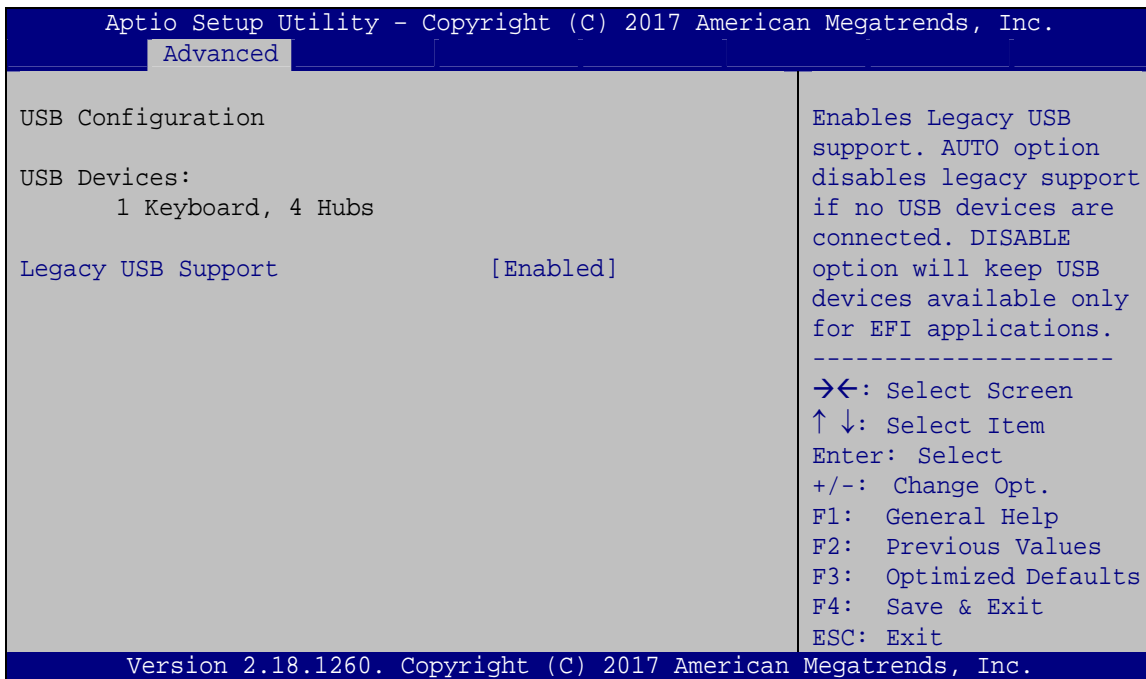

**BIOS Menu 11: USB Configuration**

➔ **USB Devices**

The **USB Devices** field lists the USB devices that are enabled on the system

## IMBA-BDE ATX Motherboard

### ➔ Legacy USB Support [Enabled]

Use the **Legacy USB Support** BIOS option to enable USB mouse and USB keyboard support. Normally if this option is not enabled, any attached USB mouse or USB keyboard does not become available until a USB compatible operating system is fully booted with all USB drivers loaded. When this option is enabled, any attached USB mouse or USB keyboard can control the system even when there is no USB driver loaded onto the system.

- ➔ **Enabled**    **DEFAULT**    Legacy USB support enabled
- ➔ **Disabled**                    Legacy USB support disabled
- ➔ **Auto**                            Legacy USB support disabled if no USB devices are connected

### 5.3.7 IEI Feature

Use the **IEI Feature** menu (**BIOS Menu 12**) to configure One Key Recovery function.

```

Aptio Setup Utility - Copyright (C) 2017 American Megatrends, Inc.
Advanced
-----
iEi Feature
Auto Recovery Function            [Disabled]
Auto Recovery Function
Reboot and recover
system automatically
within 10 min, when OS
crashes. Please install
Auto Recovery API
service before enabling
this function
-----
-><: Select Screen
↑↓: Select Item
Enter: Select
+/-: Change Opt.
F1: General Help
F2: Previous Values
F3: Optimized Defaults
F4: Save & Exit
ESC: Exit
-----
Version 2.18.1260. Copyright (C) 2017 American Megatrends, Inc.

```

**BIOS Menu 12: IEI Feature**

### ➔ Auto Recovery Function [Disabled]

Use the **Auto Recovery Function** BIOS option to enable or disable the auto recovery function of the IEI One Key Recovery.

- ➔ **Disabled**     **DEFAULT**     Auto recovery function disabled
- ➔ **Enabled**                     Auto recovery function enabled

## 5.4 IntelRCSetup

Use the **IntelRCSetup** menu (**BIOS Menu 13**) to access the processor and PCH configuration menus.

```

Aptio Setup Utility - Copyright (C) 2017 American Megatrends, Inc.
Main   Advanced IntelRCSetup Security Boot Save & Exit
-----
> Processor Configuration      Displays and provides
> PCH Configuration           option to change the
                               Processor Settings
                               -----
                               →←: Select Screen
                               ↑↓: Select Item
                               Enter: Select
                               +/-: Change Opt.
                               F1: General Help
                               F2: Previous Values
                               F3: Optimized Defaults
                               F4: Save & Exit
                               ESC: Exit

Version 2.18.1260. Copyright (C) 2017 American Megatrends, Inc.

```

**BIOS Menu 13: IntelRCSetup**

## IMBA-BDE ATX Motherboard

### 5.4.1 Processor Configuration

Use the **Processor Configuration** menu (**BIOS Menu 14**) to view detailed CPU specifications and configure its settings.

```

Aptio Setup Utility - Copyright (C) 2017 American Megatrends, Inc.
IntelRCSetup
-----
Processor Configuration
-----
Processor Socket          Socket 0
Processor ID             00050663*
Processor Frequency      2.20GHz
Processor Max Ratio      16H
Processor Min Ratio      08H
Microcode Revision       0700000C
L1 Cache RAM            128KB
L2 Cache RAM            512KB
L3 Cache RAM            3072KB
Processor 0 Version      Intel(R) Pentium(R) CPU
                        D1508 @ 2.20GHz

Hyper-Threading          [Enable]

-----
Enables Hyper Threading
(Software Method to
Enable/Disable Logical
Processor threads.

-----
-><: Select Screen
↑ ↓: Select Item
Enter: Select
+/-: Change Opt.
F1: General Help
F2: Previous Values
F3: Optimized Defaults
F4: Save & Exit
ESC: Exit

Version 2.18.1260. Copyright (C) 2017 American Megatrends, Inc.

```

#### BIOS Menu 14: Processor Configuration

##### ➔ Hyper-Threading [Enabled]

Use the **Hyper-Hhreading** BIOS option to enable or disable the Intel Hyper-Threading Technology.

- ➔ **Disabled**                      Disables the Intel Hyper-Threading Technology.
- ➔ **Enabled**    **DEFAULT**      Enables the Intel Hyper-Threading Technology.



### 5.4.2 PCH Configuration

Use the **PCH Configuration** menu (**BIOS Menu 15**) to configure the PCH parameters.

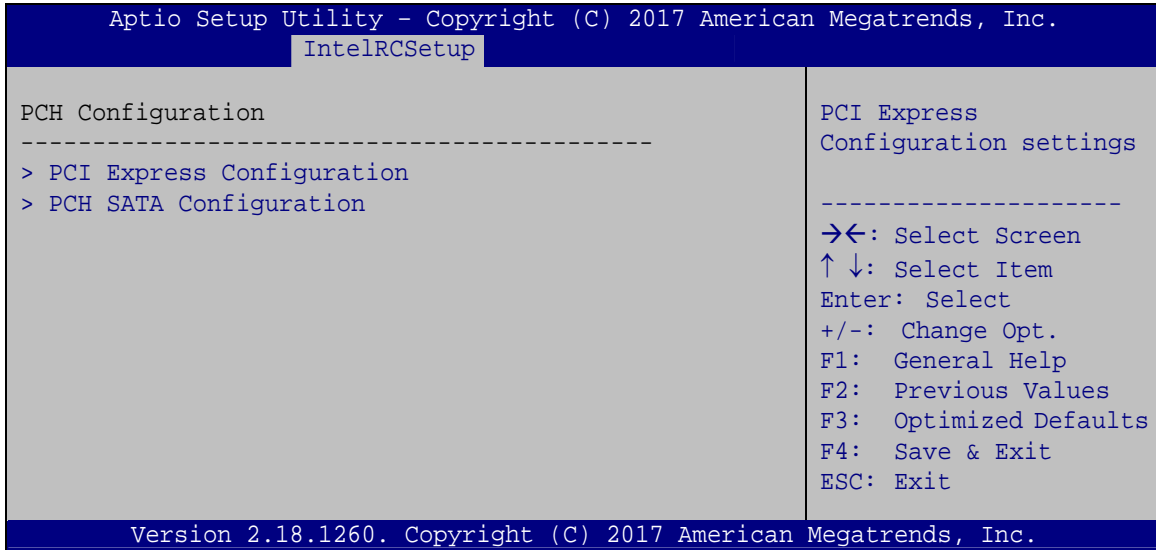

**BIOS Menu 15: PCH Configuration**

#### 5.4.2.1 PCI Express Configuration

Use the **PCI Express Configuration** menu (**BIOS Menu 16**) to configure the PCIE2X4\_1 slot.

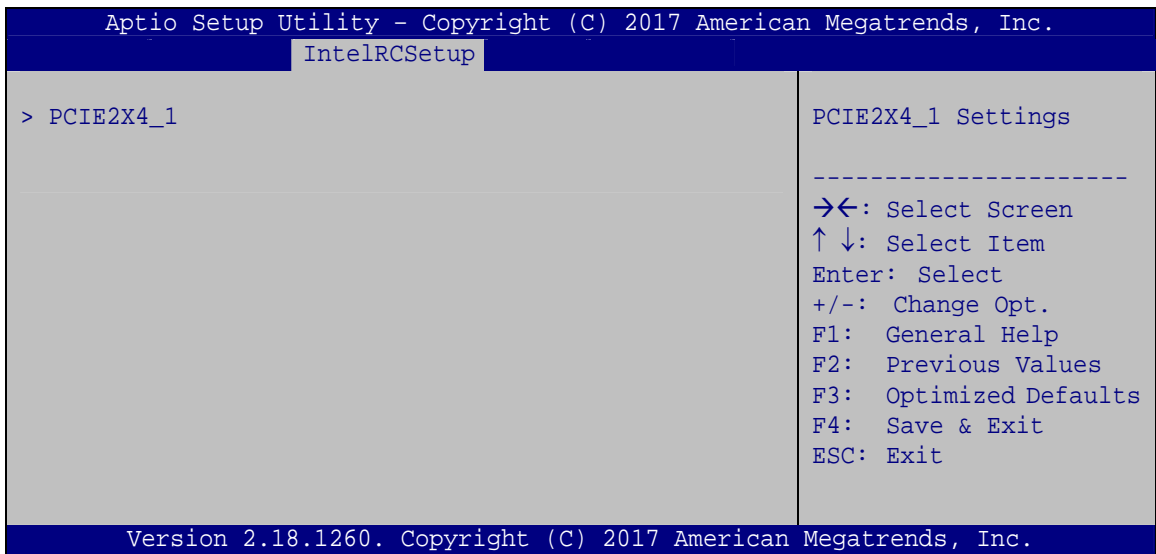

**BIOS Menu 16: PCI Express Configuration**

## IMBA-BDE ATX Motherboard

### → PCIe Speed [Auto]

Use the **PCIe Speed** option to configure the PCIe Express slot speed.

- Auto                   **DEFAULT**
- Gen 1
- Gen 2

### 5.4.2.2 PCH SATA Configuration

Use the **PCH SATA Configuration** menu (**BIOS Menu 17**) to change and/or set the configuration of the SATA devices installed in the system.

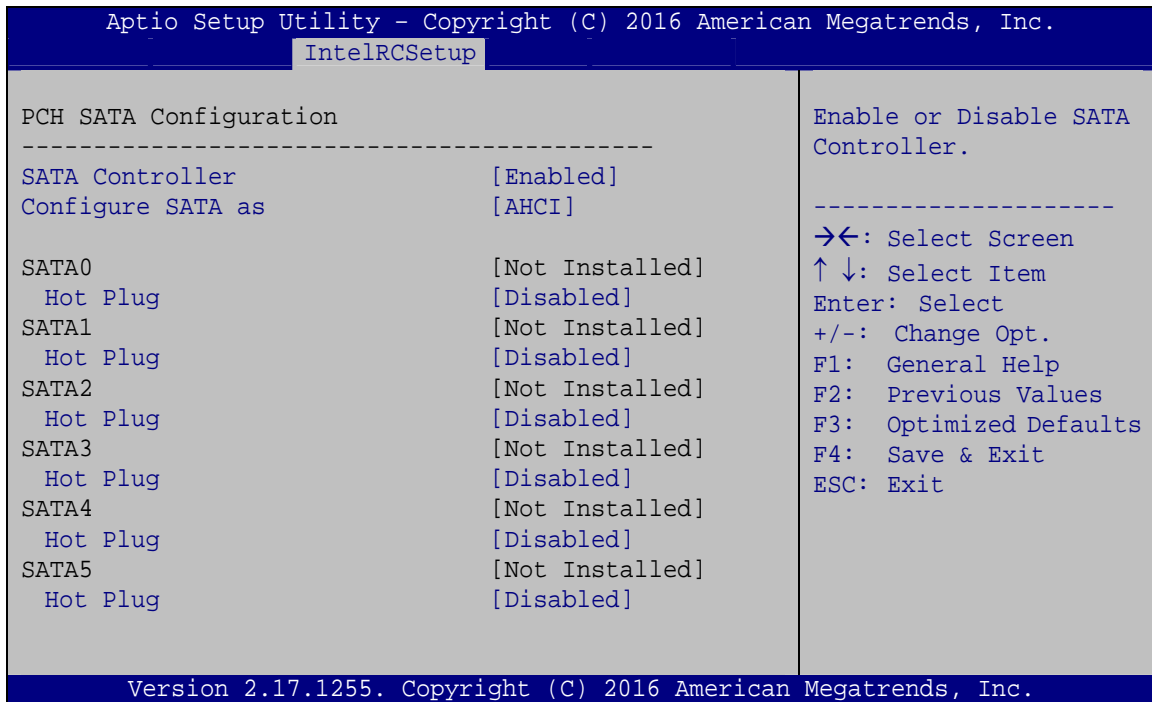

#### BIOS Menu 17: PCH SATA Configuration

### → SATA Controller [Enabled]

Use the **SATA Controller** option to configure the SATA controller.

- **Enabled**           **DEFAULT**    Enables the on-board SATA controller.
- **Disabled**                            Disables the on-board SATA controller.



## IMBA-BDE ATX Motherboard

### ➔ Administrator Password

Use the **Administrator Password** to set or change an administrator password.

### ➔ User Password

Use the **User Password** to set or change a user password.

## 5.6 Boot

Use the **Boot menu (BIOS Menu 19)** to configure system boot options.

```

Aptio Setup Utility - Copyright (C) 2017 American Megatrends, Inc.
Main      Advanced IntelRCSetup Security Boot Save & Exit
-----
Boot Configuration
Bootup NumLock State      [On]
Quiet Boot                 [Enabled]
UEFI Boot                  [Disabled]

Driver Option Priorities
Launch PXE OpROM          [Disabled]
Option ROM Messages       [Force BIOS]

Boot Option Priorities

-----
Select the keyboard
NumLock state

-----
-><: Select Screen
↑ ↓: Select Item
Enter: Select
+/-: Change Opt.
F1:  General Help
F2:  Previous Values
F3:  Optimized Defaults
F4:  Save & Exit
ESC: Exit

Version 2.18.1260. Copyright (C) 2017 American Megatrends, Inc.

```

### BIOS Menu 19: Boot

#### ➔ Bootup NumLock State [On]

Use the **Bootup NumLock State** BIOS option to specify if the number lock setting must be modified during boot up.

- |   |           |                |  |
|---|-----------|----------------|--|
| ➔ | <b>On</b> | <b>DEFAULT</b> | Allows the Number Lock on the keyboard to be enabled automatically when the computer system boots up. This allows the immediate use of the 10-key numeric keypad located on the right side of the keyboard. To confirm this, the Number Lock LED light on the keyboard is lit. |
|---|-----------|----------------|--|

→ **Off** Does not enable the keyboard Number Lock automatically. To use the 10-keys on the keyboard, press the Number Lock key located on the upper left-hand corner of the 10-key pad. The Number Lock LED on the keyboard lights up when the Number Lock is engaged.

→ **Quiet Boot [Enabled]**

Use the **Quiet Boot** BIOS option to select the screen display when the system boots.

- **Disabled** Normal POST messages displayed
- **Enabled** **DEFAULT** OEM Logo displayed instead of POST messages

→ **UEFI Boot [Disabled]**

Use the **UEFI Boot** BIOS option to allow the system to boot from the UEFI devices.

- **Disabled** **DEFAULT** Disables to boot from the UEFI devices.
- **Enabled** Enables to boot from the UEFI devices.

→ **Launch PXE OpROM [Disabled]**

Use the **Launch PXE OpROM** option to enable or disable boot option for legacy network devices.

- **Disabled** **DEFAULT** Ignore all PXE Option ROMs
- **Enabled** Load PXE Option ROMs.

→ **Option ROM Messages [Force BIOS]**

Use the **Option ROM Messages** option to set the Option ROM display mode.

- **Force BIOS** **DEFAULT** Sets display mode to force BIOS.
- **Keep Current** Sets display mode to current.

## IMBA-BDE ATX Motherboard

### 5.7 Save & Exit

Use the **Save & Exit** menu (**BIOS Menu 20**) to load default BIOS values, optimal failsafe values and to save configuration changes.

```

Aptio Setup Utility - Copyright (C) 2017 American Megatrends, Inc.
Main   Advanced IntelRCSetup Security Boot   Save & Exit
-----
Save Changes and Reset
Discard Changes and Reset

Restore Defaults
Save as User Defaults
Restore User Defaults

Reset the system after
saving the changes.

-----
-><: Select Screen
↑ ↓: Select Item
Enter: Select
+/-: Change Opt.
F1: General Help
F2: Previous Values
F3: Optimized
Defaults
F4: Save & Exit
ESC: Exit

Version 2.18.1260. Copyright (C) 2017 American Megatrends, Inc.

```

#### BIOS Menu 20: Save & Exit

##### ➔ Save Changes and Reset

Use the **Save Changes and Reset** option to save the changes made to the BIOS options and reset the system.

##### ➔ Discard Changes and Reset

Use the **Discard Changes and Reset** option to exit the system without saving the changes made to the BIOS configuration setup program.

##### ➔ Restore Defaults

Use the **Restore Defaults** option to load the optimal default values for each of the parameters on the Setup menus. **F3 key can be used for this operation.**

##### ➔ Save as User Defaults

Use the **Save as User Defaults** option to save the changes done so far as user defaults.

##### ➔ Restore User Defaults

Use the **Restore User Defaults** option to restore the user defaults to all the setup options.

Appendix

**A**

# Regulatory Compliance

---

### DECLARATION OF CONFORMITY



This equipment has been tested and found to comply with specifications for CE marking. If the user modifies and/or installs other devices in the equipment, the CE conformity declaration may no longer apply.

### FCC WARNING



This equipment complies with Part 15 of the FCC Rules. Operation is subject to the following two conditions:

- This device may not cause harmful interference, and
- This device must accept any interference received, including interference that may cause undesired operation.

This equipment has been tested and found to comply with the limits for a Class A digital device, pursuant to part 15 of the FCC Rules. These limits are designed to provide reasonable protection against harmful interference when the equipment is operated in a commercial environment. This equipment generates, uses, and can radiate radio frequency energy and, if not installed and used in accordance with the instruction manual, may cause harmful interference to radio communications. Operation of this equipment in a residential area is likely to cause harmful interference in which case the user will be required to correct the interference at his own expense.



Appendix

**B**

# Product Disposal

---

## IMBA-BDE ATX Motherboard

**CAUTION:**

Risk of explosion if battery is replaced by an incorrect type. Only certified engineers should replace the on-board battery.

Dispose of used batteries according to instructions and local regulations.

- Outside the European Union – If you wish to dispose of used electrical and electronic products outside the European Union, please contact your local authority so as to comply with the correct disposal method.
- Within the European Union – The device that produces less waste and is easier to recycle is classified as electronic device in terms of the European Directive 2012/19/EU (WEEE), and must not be disposed of as domestic garbage.

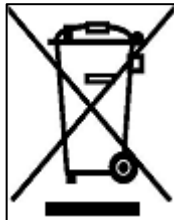

EU-wide legislation, as implemented in each Member State, requires that waste electrical and electronic products carrying the mark (left) must be disposed of separately from normal household waste. This includes monitors and electrical accessories, such as signal cables or power cords. When you need to dispose of your device, please follow the guidance of your local authority, or ask the shop where you purchased the product. The mark on electrical and electronic products only applies to the current European Union Member States.

Please follow the national guidelines for electrical and electronic product disposal.

Appendix

C

# BIOS Options

---

## IMBA-BDE ATX Motherboard

Below is a list of BIOS configuration options in the BIOS chapter.

<b>System Date [xx/xx/xx]</b> .....	<b>63</b>
<b>System Time [xx:xx:xx]</b> .....	<b>63</b>
<b>Restore AC Power Loss [Last State]</b> .....	<b>64</b>
<b>Security Device Support [Enable]</b> .....	<b>65</b>
<b>Serial Port [Enabled]</b> .....	<b>67</b>
<b>Change Settings [Auto]</b> .....	<b>67</b>
<b>Serial Port [Enabled]</b> .....	<b>68</b>
<b>Change Settings [Auto]</b> .....	<b>68</b>
<b>Serial Port [Enabled]</b> .....	<b>69</b>
<b>Change Settings [Auto]</b> .....	<b>69</b>
<b>Serial Port [Enabled]</b> .....	<b>70</b>
<b>Change Settings [Auto]</b> .....	<b>70</b>
<b>Serial Port [Enabled]</b> .....	<b>71</b>
<b>Change Settings [Auto]</b> .....	<b>71</b>
<b>Serial Port [Enabled]</b> .....	<b>72</b>
<b>Change Settings [Auto]</b> .....	<b>72</b>
<b>PC Health Status</b> .....	<b>73</b>
<b>FAN(CN4) Smart Fan Control/FAN(CN5) Smart Fan Control [Auto Mode]</b> .....	<b>74</b>
<b>Auto mode fan start/off temperature</b> .....	<b>75</b>
<b>Auto mode fan start PWM</b> .....	<b>75</b>
<b>Auto mode fan slope PWM</b> .....	<b>75</b>
<b>Wake system with Fixed Time [Disabled]</b> .....	<b>76</b>
<b>Console Redirection [Disabled]</b> .....	<b>77</b>
<b>Terminal Type [ANSI]</b> .....	<b>78</b>
<b>Bits per second [115200]</b> .....	<b>78</b>
<b>Data Bits [8]</b> .....	<b>78</b>
<b>Parity [None]</b> .....	<b>78</b>
<b>Stop Bits [1]</b> .....	<b>79</b>
<b>Legacy Serial Redirection Port [COM1]</b> .....	<b>80</b>
<b>USB Devices</b> .....	<b>80</b>
<b>Legacy USB Support [Enabled]</b> .....	<b>81</b>
<b>Auto Recovery Function [Disabled]</b> .....	<b>82</b>
<b>Hyper-Threading [Enabled]</b> .....	<b>83</b>

PCIe Speed [Auto].....	85
SATA Controller [Enabled].....	85
Configure SATA as [AHCI].....	86
Hot Plug [Disabled].....	86
Administrator Password .....	87
User Password .....	87
Bootup NumLock State [On].....	87
Quiet Boot [Enabled] .....	88
UEFI Boot [Disabled] .....	88
Launch PXE OpROM [Disabled].....	88
Option ROM Messages [Force BIOS].....	88
Save Changes and Reset .....	89
Discard Changes and Reset .....	89
Restore Defaults .....	89
Save as User Defaults .....	89
Restore User Defaults .....	89

Appendix

**D**

# Terminology

---

<b>AC '97</b>	Audio Codec 97 (AC'97) refers to a codec standard developed by Intel® in 1997.
<b>ACPI</b>	Advanced Configuration and Power Interface (ACPI) is an OS-directed configuration, power management, and thermal management interface.
<b>AHCI</b>	Advanced Host Controller Interface (AHCI) is a SATA Host controller register-level interface.
<b>ATA</b>	The Advanced Technology Attachment (ATA) interface connects storage devices including hard disks and CD-ROM drives to a computer.
<b>ARMD</b>	An ATAPI Removable Media Device (ARMD) is any ATAPI device that supports removable media, besides CD and DVD drives.
<b>ASKIR</b>	Amplitude Shift Keyed Infrared (ASKIR) is a form of modulation that represents a digital signal by varying the amplitude (“volume”) of the signal. A low amplitude signal represents a binary 0, while a high amplitude signal represents a binary 1.
<b>BIOS</b>	The Basic Input/Output System (BIOS) is firmware that is first run when the computer is turned on and can be configured by the end user
<b>CODEC</b>	The Compressor-Decompressor (CODEC) encodes and decodes digital audio data on the system.
<b>CompactFlash®</b>	CompactFlash® is a solid-state storage device. CompactFlash® devices use flash memory in a standard size enclosure. Type II is thicker than Type I, but a Type II slot can support both types.
<b>CMOS</b>	Complimentary metal-oxide-conductor is an integrated circuit used in chips like static RAM and microprocessors.
<b>COM</b>	COM refers to serial ports. Serial ports offer serial communication to expansion devices. The serial port on a personal computer is usually a male DB-9 connector.
<b>DAC</b>	The Digital-to-Analog Converter (DAC) converts digital signals to analog signals.
<b>DDR</b>	Double Data Rate refers to a data bus transferring data on both the rising and falling edges of the clock signal.

## IMBA-BDE ATX Motherboard

<b>DMA</b>	Direct Memory Access (DMA) enables some peripheral devices to bypass the system processor and communicate directly with the system memory.
<b>DIMM</b>	Dual Inline Memory Modules are a type of RAM that offer a 64-bit data bus and have separate electrical contacts on each side of the module.
<b>DIO</b>	The digital inputs and digital outputs are general control signals that control the on/off circuit of external devices or TTL devices. Data can be read or written to the selected address to enable the DIO functions.
<b>EHCI</b>	The Enhanced Host Controller Interface (EHCI) specification is a register-level interface description for USB 2.0 Host Controllers.
<b>EIDE</b>	Enhanced IDE (EIDE) is a newer IDE interface standard that has data transfer rates between 4.0 MBps and 16.6 MBps.
<b>EIST</b>	Enhanced Intel® SpeedStep Technology (EIST) allows users to modify the power consumption levels and processor performance through application software. The application software changes the bus-to-core frequency ratio and the processor core voltage.
<b>FSB</b>	The Front Side Bus (FSB) is the bi-directional communication channel between the processor and the Northbridge chipset.
<b>GbE</b>	Gigabit Ethernet (GbE) is an Ethernet version that transfers data at 1.0 Gbps and complies with the IEEE 802.3-2005 standard.
<b>GPIO</b>	General purpose input
<b>HDD</b>	Hard disk drive (HDD) is a type of magnetic, non-volatile computer storage device that stores digitally encoded data.
<b>ICH</b>	The Input/Output Control Hub (ICH) is an Intel® Southbridge chipset.
<b>IrDA</b>	Infrared Data Association (IrDA) specify infrared data transmission protocols used to enable electronic devices to wirelessly communicate with each other.
<b>L1 Cache</b>	The Level 1 Cache (L1 Cache) is a small memory cache built into the system processor.
<b>L2 Cache</b>	The Level 2 Cache (L2 Cache) is an external processor memory cache.



<b>LCD</b>	Liquid crystal display (LCD) is a flat, low-power display device that consists of two polarizing plates with a liquid crystal panel in between.
<b>LVDS</b>	Low-voltage differential signaling (LVDS) is a dual-wire, high-speed differential electrical signaling system commonly used to connect LCD displays to a computer.
<b>POST</b>	The Power-on Self Test (POST) is the pre-boot actions the system performs when the system is turned-on.
<b>RAM</b>	Random Access Memory (RAM) is volatile memory that loses data when power is lost. RAM has very fast data transfer rates compared to other storage like hard drives.
<b>SATA</b>	Serial ATA (SATA) is a serial communications bus designed for data transfers between storage devices and the computer chipsets.
<b>S.M.A.R.T</b>	Self Monitoring Analysis and Reporting Technology (S.M.A.R.T) refers to automatic status checking technology implemented on hard disk drives.
<b>UART</b>	Universal Asynchronous Receiver-transmitter (UART) is responsible for asynchronous communications on the system and manages the system's serial communication (COM) ports.
<b>UHCI</b>	The Universal Host Controller Interface (UHCI) specification is a register-level interface description for USB 1.1 Host Controllers.
<b>USB</b>	The Universal Serial Bus (USB) is an external bus standard for interfacing devices. USB 1.1 supports 12Mbps data transfer rates and USB 2.0 supports 480Mbps data transfer rates.
<b>VGA</b>	The Video Graphics Array (VGA) is a graphics display system developed by IBM.

Appendix

**E**

# Digital I/O Interface

---

## E.1 Introduction

The DIO connector on the IMBA-BDE is interfaced to GPIO ports on the Super I/O chipset. The digital inputs and digital outputs are generally control signals that control the on/off circuit of external devices or TTL devices. Data can be read or written to the selected address to enable the DIO functions.



**NOTE:**

For further information, please refer to the datasheet for the Super I/O chipset.

The BIOS interrupt call **INT 15H** controls the digital I/O.

**INT 15H:**

<b>AH – 6FH</b>	
<u>Sub-function:</u>	
<b>AL – 8</b>	: Set the digital port as INPUT
<b>AL</b>	: Digital I/O input value

## IMBA-BDE ATX Motherboard

### E.2 Assembly Language Sample 1

```

MOV     AX, 6F08H      ;setting the digital port as input
INT     15H           ;
    
```

AL low byte = value

<b>AH – 6FH</b>
<u>Sub-function:</u>
<b>AL – 9</b> : Set the digital port as OUTPUT
<b>BL</b> : Digital I/O input value

### E.3 Assembly Language Sample 2

```

MOV     AX, 6F09H      ;setting the digital port as output
MOV     BL, 09H        ;digital value is 09H
INT     15H           ;
    
```

Digital Output is 1001b

Appendix

**F**

# Hazardous Materials Disclosure

---

## IMBA-BDE ATX Motherboard

The details provided in this appendix are to ensure that the product is compliant with the Peoples Republic of China (China) RoHS standards. The table below acknowledges the presences of small quantities of certain materials in the product, and is applicable to China RoHS only.

A label will be placed on each product to indicate the estimated “Environmentally Friendly Use Period” (EFUP). This is an estimate of the number of years that these substances would “not leak out or undergo abrupt change.” This product may contain replaceable sub-assemblies/components which have a shorter EFUP such as batteries and lamps. These components will be separately marked.

Please refer to below table.

Part Name	Toxic or Hazardous Substances and Elements					
	Lead (Pb)	Mercury (Hg)	Cadmium (Cd)	Hexavalent Chromium (CR(VI))	Polybrominated Biphenyls (PBB)	Polybrominated Diphenyl Ethers (PBDE)
Housing	O	O	O	O	O	O
Display	O	O	O	O	O	O
Printed Circuit Board	O	O	O	O	O	O
Metal Fasteners	O	O	O	O	O	O
Cable Assembly	O	O	O	O	O	O
Fan Assembly	O	O	O	O	O	O
Power Supply Assemblies	O	O	O	O	O	O
Battery	O	O	O	O	O	O

O: This toxic or hazardous substance is contained in all of the homogeneous materials for the part is below the limit requirement in SJ/T11363-2006 (now replaced by GB/T 26572-2011).

X: This toxic or hazardous substance is contained in at least one of the homogeneous materials for this part is above the limit requirement in SJ/T11363-2006 (now replaced by GB/T 26572-2011).

此附件旨在确保本产品符合中国 RoHS 标准。以下表格标示此产品中某有毒物质的含量符合中国 RoHS 标准规定的限量要求。

本产品上会附有“环境友好使用期限”的标签，此期限是估算这些物质“不会有泄漏或突变”的年限。本产品可能包含有较短的环境友好使用期限的可替换元件，像是电池或灯管，这些元件将会单独标示出来。

部件名称	有毒有害物质或元素					
	铅 (Pb)	汞 (Hg)	镉 (Cd)	六价铬 (CR(VI))	多溴联苯 (PBB)	多溴二苯 醚 (PBDE)
壳体	○	○	○	○	○	○
显示	○	○	○	○	○	○
印刷电路板	○	○	○	○	○	○
金属螺帽	○	○	○	○	○	○
电缆组装	○	○	○	○	○	○
风扇组装	○	○	○	○	○	○
电力供应组装	○	○	○	○	○	○
电池	○	○	○	○	○	○

○: 表示该有毒有害物质在该部件所有物质材料中的含量均在 SJ/T 11363-2006 (现由 GB/T 26572-2011 取代) 标准规定的限量要求以下。

X: 表示该有毒有害物质至少在该部件的某一均质材料中的含量超出 SJ/T 11363-2006 (现由 GB/T 26572-2011 取代) 标准规定的限量要求。